

ENFORCER[®] **Sensor**

Single Photobeam Sensor

E-961-S90W

Range: 90ft. (30m)



INSTALLATION MANUAL

Features:

- Infrared single photobeam sensor.
- Range: Up to 90 feet (30m)
- IP-66 weatherproof protection.
- For indoor and outdoor use.
- 10~24V AC/DC input voltage.
- Horizontal and vertical adjustment for easy alignment.
- N.C./N.O./COM relay outputs.
- Adjustable low or high sensor beam brightness.

Typical Applications:

- Safety sensor for garage doors or outdoor gates.
- Overhead door security sensor.
- Industrial automation – detect small objects on a manufacturing line.
- Entry detection for store fronts.
- Assist in measuring parking distance.
- Alarm sensor.

Fig. 1 - Included

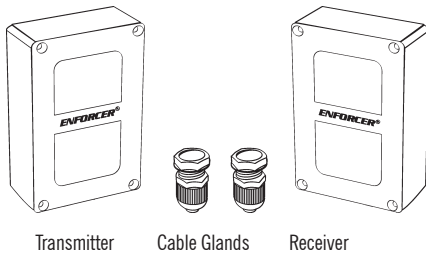

Dimensions:

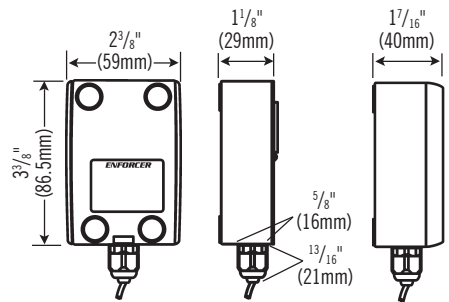

Caution:

- This sensor was not designed to prevent bodily injury or loss of life.
- This sensor was not designed for use in environments where there is the possibility of explosive gasses present.
- Use of this sensor in certain security applications may be regulated by local laws or codes. SECO-LARM is not responsible for compliance with such laws or codes.

Fig. 2 - Sensor

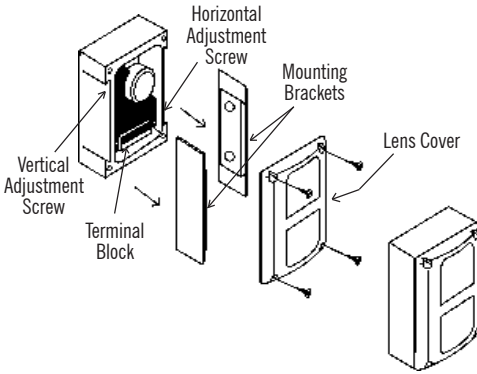

Fig. 3 - Cable Gland

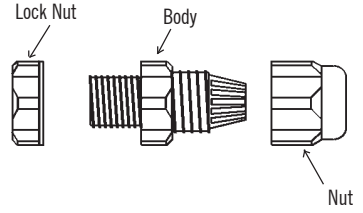

Fig. 4 - Sample Installations

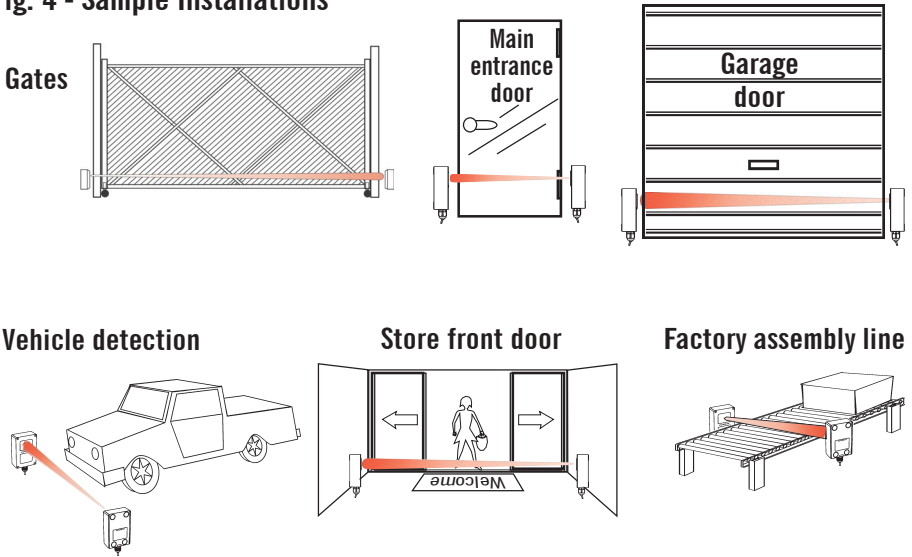
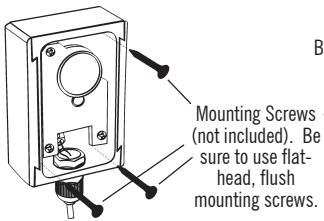

Fig. 5 - Mounting

Flush Mount



Perpendicular Mount

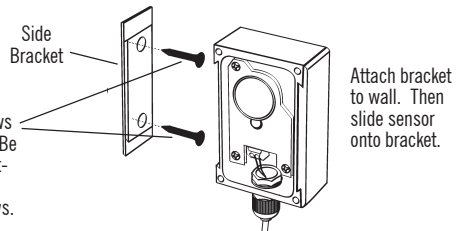
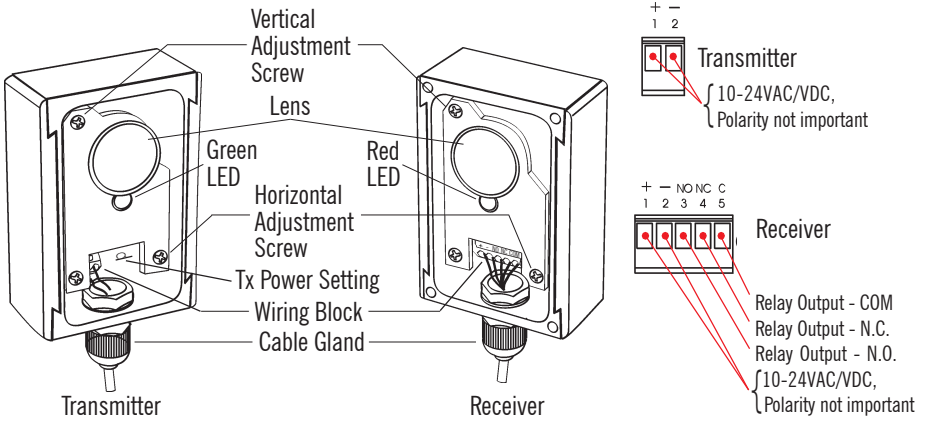

Fig. 6 - Wiring and Adjusting



Installation and Alignment:

LED functions:

- GREEN LED – When ON, indicates power is present.
- RED LED – When ON, indicates the sensor is aligned properly.
- When OFF, indicates the sensor is not aligned properly, or the beam has been interrupted.

Installation:

1. Install one cable gland in the bottom of the transmitter, and one in the bottom of the receiver:
 - a. Remove the lens cover.
 - b. Carve out the holes in the transmitter and receiver with a sharp tool.
 - c. Take the lock nut off the cable gland (see fig. 3), insert the cable gland into the hole from the bottom, and tighten with the lock nut.
2. Wire the unit – Run the wires to where the sensor is to be mounted. Keep wires hidden where possible, and expose them only at the very end where needed to connect to the transmitter and receiver. (see fig.6)
3. Decide where to mount:
 - a. The transmitter and receiver should be facing each other.
 - b. The units should not interfere with normal movement around the protected area.
4. Initial test – Temporarily hold the transmitter and receiver to the wall where they are to be mounted and power up the units to test alignment before permanent mounting. (See Power and Alignment below.)
5. Mount the transmitter/receiver (flush mount) (fig. 5)
 - Mount flush to the wall with three mounting screws (not included).

6. Mount the transmitter/receiver (perpendicular mount) (fig. 5):
 - a. Depending on how mounted, remove one of the two side brackets.
 - b. Screw the side bracket into the wall using two mounting screws (not included).
 - c. Slide the transmitter or receiver onto the side bracket.

Power and Alignment

1. Power up the transmitter and receiver. The green LED on the transmitter should turn ON to indicate power is present. The red LED on the receiver should turn ON to indicate the two are aligned properly.
 2. Alignment – If the receiver is connected to power, and if the red LED does not turn on while the green LED is on, the transmitter and receiver are not aligned. Loosen or tighten the horizontal and vertical adjustment screws on the transmitter and/or receiver until the red LED turns on, indicating alignment. (Fig. 6)
- NOTE – If two or more E-961-S90W pairs are installed within close proximity of each other, adjust the sensor beam brightness to “low” by cutting the wire loop on the transmitter circuit board just above the “TX” marking.

Testing:

1. Do a walk-through test. Walk between the transmitter and receiver. This should break the beam, turn the red LED off, and trigger the alarm panel or warning device.
2. Replace the lens covers on the transmitter and receiver. Test again one last time.

Specifications:

Technology:	Through-beam photoelectric sensor
Sensing range	90 feet (30 meters)
Input voltage	10~24 VAC/VDC
Response time	100ms
Emitting element	Infrared LED
Operation indicator	Red LED on for standby (TX) / Green LED show power (RX)
Current consumption	33.5mA (TX), 27.5mA (beam aligned) / 13mA (beam broken) (RX)
Relay	1A, 120VAC, N.O./N.C./COM
Tx power adjust.	Low vs. high
Sensing angle adjust	Horizontal +/-5°, vertical +/-5°
Illumination	Lamplight <10,000 lux, sunlight <30,000 lux
Noise resistance	1,500 Vp-P/1us
Surge resistance	2KV/1us
Vibration resistance	10~55 Hz/1.5mm, 2 hours in X.Y.Z. phase
Material	Case — nylon, lens — polycarbonate
Operating temp.	-13°~140°F (-25°~60°C)
Weather-Proof	IP-66 standard
Approvals	CE standard

Troubleshooting:

Trouble	Possible Origin(s)	Remedy(s)
Sensor does not detect the object.	1) Sensor sensitivity is not properly set. 2) Object may have a reflective surface which confuses sensor.	Change the angle of the sensor or readjust the sensitivity setting.
Red LED does not turn on.	1) Dirty sensor and/or reflector. 2) Reflector and/or sensor is misaligned.	1) Clean the sensor and reflector with a damp (not wet) cloth. 2) Adjust the reflector and/or sensor for proper alignment.
Red LED lights when object is detected, but no output.	No continuity between sensor and alarm device.	Check cable from sensor to alarm device. Test sensor.

WARRANTY: ENFORCER Photobeam Sensors are warranted against defects in material and workmanship while used in normal service for a period of one (1) year from the date of sale to the original customer. Our obligation is limited to the repair or replacement of any defective part if the unit is returned, transportation pre-paid, to SECO-LARM.

NOTICE

The information and specifications printed in this manual are current at the time of publication. However, the SECO-LARM policy is one of continual development and improvement. For this reason, SECO-LARM reserves the right to change specifications without notice. SECO-LARM is also not responsible for misprints or typographical errors.

Copyright © 2004 SECO-LARM U.S.A., Inc. All rights reserved. This material may not be reproduced or copied, in whole or in part, without the written permission of SECO-LARM.

SECO-LARM® U.S.A., Inc.

16842 Millikan Avenue, Irvine, CA 92606
Tel: 800-662-0800 / 949-261-2999 Fax: 949-261-7326

Website: www.seco-larm.com
E-mail: sales@seco-larm.com

 PITSW3
MIE961S90W.PMD