

SECO-LARM®



SM-217Q / SM-317Q (WIDE-GAP MOUNT)

ALARM CIRCUIT:

SM-217Q – For closed circuit (CC) systems only.

SM-317Q – For open circuit (OC) systems only.

CONTACT TYPE: SPST, gold under-plating with DEACTIVATED RHODIUM outer-plating (**SECO-LARM** contacts have a unique RHODIUM plating that have gone through a special oxygen treatment to DEACTIVATE the surface and thus eliminate absorption of organic impurities, polymer growth during operation, as well as the possibility of contact freezing). This also results in a most reliable contact, especially at the lower load levels normally used in security systems.

SWITCH CYCLES: 50 million.

OPERATION GAP: **SM-217Q** – 2 inch.

SM-317Q – 1⁷/₈ inch.

APPLICATIONS: Designed primarily for use with loosely fitted windows and misaligned doors. The magnet will operate the contact from almost any direction, making those hard-to-mount installations simple. For mounting on steel doors, windows, etc., use of a spacer or stronger magnet may be necessary. Contact **SECO-LARM** or your local distributor for more information.

COLORS: White, Mahogany brown, Grey (specify).

CASE CONSTRUCTION: Weatherproof, high-impact ABS plastic. Screw terminals with recessed mounting screw to make any installation more attractive.

MAGNET: Extra-strength Alnico 5 for greater pulling power and longer life.

RATING:

SM-217Q 0.1Amp./100VDC (max.)
1Amp./10VDC (max.)
10W (max.)

SM-317Q 0.02Amp./100VDC (max.)
0.2Amp./10VDC (max.)
3W (max.)

TEMPERATURE: -15°F to 160°F (-25°C to 70°C).

Note: Products with model number that ends with "Q" or have a round green "Q" sticker represents RoHS compliant products.

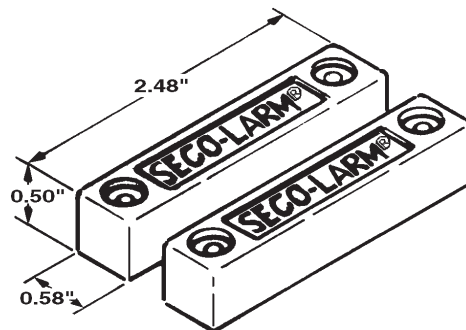

PRODUCT INFO. **SM-217Q/SM-317Q**
(WIDE-GAP MOUNT)