

BEFORE CONNECTING TO LOW VOLTAGE DEVICES:

- Check the DIP switch setting to ensure correct voltage (6VDC, 12VDC, or 24VDC).
- With power turned on, check the wires connected to each terminal pair to ensure correct voltage.

Installation Manual

ENFORCER[®]

PS-D1610-BUQ (Blade fuse)

PS-D1610-PUQ (PTC* fuse)

12VDC High current CCTV power supplies
16 Outputs, selectable 6/12/24 VDC, 10A@12VDC

Features:

- Adjustable VDC outputs:
 - Output voltage can be adjusted with the potentiometer to compensate for voltage drop.
 - Each output is individually fused.
 - Output fuses rated 3A@250VAC.
 - Individual red status indicator LED for each output.
 - Main power switch to turn on/off power to outputs.
- Power:
 - Input: 120VAC, 60Hz ; Output: 6/12/24VDC.
 - Main fuse rated 10A@ 250VAC.
 - Spare main fuse and channel fuse on board.
 - 6-ft power cord included.



PS-D1610-BUQ Shown

- Enclosure:
 - Heavy-duty steel housing to protect the power connections.
 - Removable steel cover for easy access.
 - Ventilation holes to prevent heat build-up.
 - Dimensions - 12¹/₈" x 12¹/₄" x 3⁵/₈" (308 x 311 x 91 mm).
 - Knock-out on the cover for an optional cam lock.

*Positive Temperature Coefficient

Introduction:

This ENFORCER PS-D1610 series power supply centralizes the CCTV system's power input, power transformer, DC regulator, and independently-fused power outputs into one heavy-duty, easy-to-install enclosure.

Installation Notes:

- **DOUBLE-CHECK VOLTAGE SETTINGS BEFORE CONNECTING THE CAMERAS.**
- Indoor use only - Do not install where the unit will be exposed to rain or moisture.
- For professional use only.
- Installation must conform to all local codes.

Installation:

1. Find a good location. Mount the enclosure out of sight and protected from moisture, but where an authorized service person can have access.
NOTE: Make sure the space where the enclosure is to be mounted has adequate ventilation. Otherwise, heat buildup inside the enclosure could damage the electronic parts or cause the PTC fuses to trip unnecessarily.
2. Locate the enclosure mounting holes. Using the enclosure as a template**, mark the location of one of the two upper screws on the wall with a pencil. Fasten one 5/32" x 1" (4 x 26mm) screw (not included) until the gap between the wall and the screw head is approximately 1/4" (6mm). Hang the enclosure on this screw and adjust the proper angle of the enclosure. Repeat with the second screw. Then mark up and securely fasten the enclosure with all four screws.

** Or mark up a paper template from the enclosure and drill after taping the template in correct position.

3. Determine how the main power line and CCTV camera cables will be run – The enclosure has knock-outs on the side, top, bottom, and rear panels for running cables. Punch the appropriate knock-outs. See Fig. 1.

NOTE: If cables are run out of the side, top, or bottom panels, protect with an electrical conduit of not more than 1" outside diameter. Wires running inside the electrical conduit must not be too tight.

4. To connect the main power cord to the small white terminal block, follow the wire color indicated on the "NEA" label that is placed beside the terminal block (i.e., white wire on top, green wire to the middle, and black wire to the bottom of the terminal block, see Fig. 2). Use the provided nut and cable clamp to fasten the power cord onto the metal enclosure in the location shown on Fig. 2 if necessary. A plastic snap bushing is also provided for the power cord hole.

FIG. 1: Knockouts for running cables

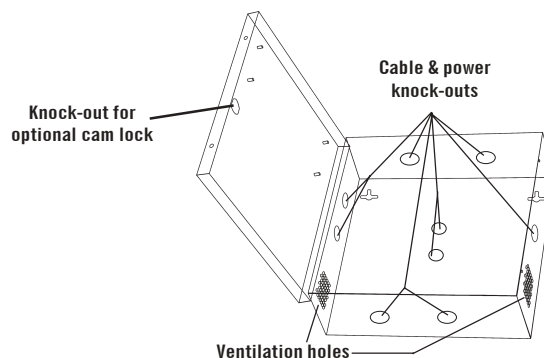

CCTV DC Power Supply Installation Manual

- Connect the power input wires of the CCTV cameras or low-voltage devices to the PDM board (see Fig. 2). **Observe correct polarity.** The terminals marked "P" are for positive wires, and "N" are for negative wires. Each output consists of one "P" terminal and one "N" terminal.

Run wire pairs from the terminals through or along the wall to where the CCTV cameras and/or devices are mounted.

NOTE: Use minimum 18-gauge wires to minimize voltage drop.

NOTE: Test each wire pair's voltage before connecting to cameras.

- Turn the main switch ON. The green LED on the PDM board will light to show that power is present. The red LEDs on the PDM will light to show each terminal pair is working correctly.
- Test the voltage output at the end of each wire pair to see if there is significant voltage drop. The voltage output for all wire pairs should be about the same unless a voltage drop occurred on a certain wire pair. When running wires from the DC power supply, voltage drop can occur for one of three reasons:
 - The wire is too thin. Use minimum 18-gauge wire.
 - The wire has run a long distance. If a wire pair is showing significant voltage drop compared to the others, either shorten the length of the voltage drop affected wire pair, or lengthen the other wire pairs to have a similar voltage output reading on all wire pairs.
 - A large number of CCTV cameras and/or devices connected to the PDM board is causing excessive power drain across all the outputs.
- Adjust the voltage output if needed - If the voltage output reading at the end of the wire pair where it is connected to the camera or accessory falls

below the minimum voltage required, use a screwdriver to carefully turn the potentiometer located on the ST-2406-10A PCB to the right. (See Fig. 2 and Table 1.) This will increase the total voltage output from the PDM board to compensate for the voltage drop.

WARNING: Adjusting the potentiometer affects the voltage output of all the wire pairs. Using a voltage output in excess of the specified voltage level of a camera may cause damage.

- After all adjustments, turn the main switch OFF.
- Connect all the wire pairs to their respective CCTV cameras or devices. **Double-check the specified operating voltage of each CCTV cameras or devices before applying power.**

NOTE:

 - Connect a maximum of 16 CCTV cameras or devices.
 - The CCTV cameras and devices connected to the PDM must all operate on the same voltage (6VDC, 12VDC, or 24VDC).
 - The factory default is preset at 12VDC output. For 6VDC or 24VDC operation, adjust the DIP switch (see Fig. 2 and Table 1).
 - Maximum total current connected to all terminals must not exceed the power supply's total current capacity of 10 Amp at 12VDC.
- Turn the main switch ON.
- Close the steel door of the enclosure and secure it with either the provided machine screws or an optional cam lock (see fig. 3).

FIG. 2: Power Connections

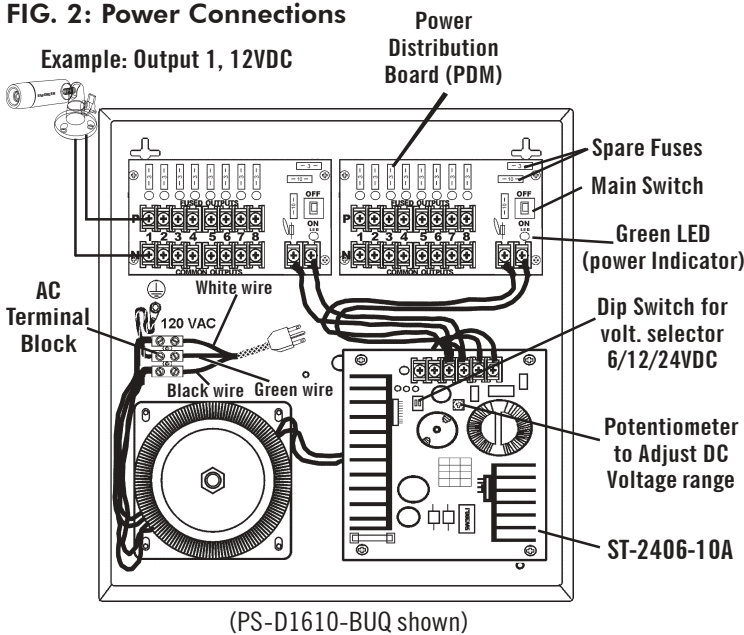

FIG. 3: Securing the Enclosure:

Close the cover, then secure with included machine screws or optional cam lock.

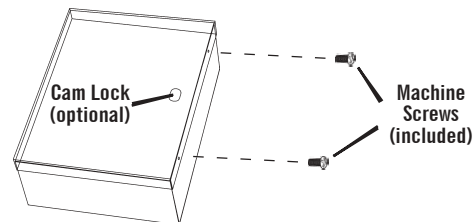

Table 1: DC Voltage Output Dip Switch Settings

Voltage	Dip SW1	Dip SW2	Voltage range @ no load
6V	ON	OFF	5.9~8.9
12V	OFF	OFF	12.6~14
24V	OFF	ON	27.6~29.5

Table 2: Max. supply current chart

Max. supply current at 6VDC	Max. supply current at 12VDC	Max. supply current at 24VDC
10 Amp.	10 Amp.	5 Amp.

The SECO-LARM® policy is one of continual development and improvement. For that reason, SECO-LARM reserves the right to change specifications without notice. SECO-LARM is not responsible for misprints.

WARRANTY: This SECO-LARM product is warranted against defects in material and workmanship while used in normal service for a period of one (1) year from the date of sale to the original consumer customer. SECO-LARM's obligation is limited to the repair or replacement of any defective part if the unit is returned, transportation prepaid, to SECO-LARM. This Warranty is void if damage is caused by or attributed to acts of God, physical or electrical misuse or abuse, neglect, repair, or alteration, improper or abnormal usage, or faulty installation, or if for any other reason SECO-LARM determines that such equipment is not operating properly as a result of causes other than defects in material and workmanship. The sole obligation of SECO-LARM, and the purchaser's exclusive remedy, shall be limited to replacement or repair only, at SECO-LARM's option. In no event shall SECO-LARM be liable for any special, collateral, incidental, or consequential personal or property damages of any kind to the purchaser or anyone else.

SECO-LARM® U.S.A., Inc., 16842 Millikan Avenue, Irvine, CA 92606
 Tel: 800-662-0800 / 949-261-2999 Fax: 949-261-7326

Website: www.seco-larm.com
 E-mail: info@seco-larm.com

MiPS-D1610-xUQ_0909.pmd
 Order Part #764-503P
 PITSW1