

Magnetic Gate Lock Installation Manual

TROUBLESHOOTING

Problem:	Possible cause:	Solutions:
Gate does not lock	No power	<ul style="list-style-type: none">• Check to make sure the wires are secure• Check that the power supply is connected and operating• Make sure the unit is wired correctly
Gate locks, but can be easily forced open	Poor contact between electromagnet and armature plate	<ul style="list-style-type: none">• Make sure the electromagnet and armature plate are properly aligned• Make sure the contact surfaces of the electromagnet and armature plate are clean and free from rust
	Incorrect voltage setting	<ul style="list-style-type: none">• Check the power leads with a meter, and make sure the correct voltage is present
Delay in gate releasing	A secondary diode was installed across the electromagnet	<ul style="list-style-type: none">• The electromagnet is fitted with a metal oxide varistor to prevent interference, so do not install a secondary diode

REGULAR MAINTENANCE

- Clean the contact surfaces of the electromagnet or armature plate with a soft cloth and non-abrasive, non-corrosive cleaner.
- Apply a light coat of a silicon lubricant to both contact surfaces and wipe away the excess to prevent rust.
- Check that the armature plate is securely attached to the door, yet can pivot slightly around the armature screw.
- Check that the electromagnet is securely attached to the gate or post.

UL CERTIFICATION

E-942FC-1300 electromagnetic lock conforms to UL/10B "Fire Tests of Door Assemblies" and UL/10C "Positive Pressure Fire Tests of Door Assemblies" for swinging door assemblies. It is also classified in accordance with the Uniform Building Code standard 7-2.

WARRANTY: ENFORCER Electromagnetic Locks are warranted against defects in material and workmanship while used in normal service for a period of one (1) year from the date of sale to the original customer. Our obligation is limited to the repair or replacement of any defective part if the unit is returned, transportation pre-paid, to SECO-LARM.

NOTICE

The information and specifications printed in this manual are current at the time of publication. However, the SECO-LARM policy is one of continual development and improvement. For this reason, SECO-LARM reserves the right to change specifications without notice. SECO-LARM is also not responsible for misprints or typographical errors.

Copyright © 2003 SECO-LARM U.S.A., Inc. All rights reserved. This material may not be reproduced or copied, in whole or in part, without the written permission of SECO-LARM.

SECO-LARM® U.S.A., Inc.

16842 Millikan Avenue, Irvine, CA 92606
Tel: 800-662-0800 / 949-261-2999 Fax: 949-261-7326

Website: www.seco-larm.com
E-mail: sales@seco-larm.com

 PITGW1

E-942FC-1300IMUe.pmd

Installation Manual

ENFORCER[®] **E-942FC-1300**

Electromagnetic Gate Lock



- For use with nearly all types of outdoor sliding and swinging electric gates.
- Holding force — 1,300 pounds (591kg).
- Can be mounted horizontally or vertically.
- Housing dimensions — 8" x 2 1/2" x 1 5/8" (202 x 62 x 40 mm).
- Armature plate dimensions — 7 1/4" x 2 3/8" x 5/8" (185 x 61 x 16 mm).
- Voltage — 12VDC or 24VDC, with current draw of 500mA at 12VDC (250mA @ 24VDC).
- Cable — 6.5' (2 meters), with standard conduit connector (3/4" outside diameter, 1/2" inside diameter).



MOUNTING THE E-942FC-1300

A. Determine type of gate:

1. **Single-swing gate** (fig. 2) — Gate swings on one end, and comes to rest on a fixed gate post when closed. In this case, a typical installation has the electromagnet fixed to the gate post, and the armature connected to the free end of the gate with a Z-bracket.
2. **Double-swing gate** (fig. 3) — Two gates swing in the same direction when activated. The electromagnet is fixed to the free end of one gate, and the armature is fixed to the free end of the other via a Z-bracket. **IMPORTANT:**
 - a. A cover piece should be added to the Z-bracket to cover the electromagnet. This will help prevent unauthorized users from prying the armature and the electromagnet apart.
 - b. Because of the cover piece, it is important to coordinate the swing of the gates to prevent the electromagnet from catching on the cover piece. In this case, the gate with the armature should open before the gate with the electromagnet.
3. **Sliding gate** (fig. 4) — The gate slides instead of swings away from a fixed gate post. In this case, use L-brackets to mount the electromagnet and the armature perpendicular to each other.

B. Mount the electromagnet (fig. 5) — In most cases, the position of the electromagnet will determine the location of the armature plate. Make sure there is space to run the cable.

Note: For hollow door headers or gate posts using blind nuts (see figure 6):

1. Tape the template to the appropriate location.
2. Drill four 9.5mm holes, one for each short hex screw. **IMPORTANT:** The holes must be 9.5mm. No smaller, no larger.
3. Insert a blind nut in one of the 9.5mm holes.
4. Put the washer on the M6x30 screw. Then put the hex tool on the screw. Then turn the screw by hand into the blind nut.
5. Use a wrench or vice-grip to tightly hold the hex tool. Then use the included Allen wrench to slowly tighten the screw until it does not turn any further. This compresses the blind nut so that it remains permanently fixed in the hole.
6. Remove the screw.
7. Repeat steps 3) through 6) for the other three blind nuts.
8. Push hex screws into each of the four screw holes in the electromagnet. Use the Allen wrench to tighten the screws into the blind nuts.

Magnetic Gate Lock Installation Manual

- C. Mount the armature (fig. 5) — Once the electromagnet is mounted, determine the correct position of the armature. Use the appropriate L-bracket or Z-bracket to position the armature so that it will lay against the electromagnet when activated. However, leave a slight gap between the two so that the armature does not slam against the electromagnet when the gate is closed.
1. Put one rubber washer between two steel washers, and place them over the armature screw between the armature and the bracket. This will allow the armature to pivot slightly around the armature screw in order to compensate for gate misalignment.
 2. Make sure the guide pins are inserted into guide holes to prevent the armature from spinning.
 3. Tighten the sexnut enough so the armature can withstand the force of someone attempting to pry the gate open while the electromagnet is engaged.
 4. Do not tighten the armature against the bracket. The armature must be able to pivot around the armature screw.
- D. Cover the installation — Use a steel box to make the installation more attractive as well as prevent unauthorized users from prying the armature and electromagnet apart when engaged.
- E. Run the wires — The goal is to keep as little of the wires exposed as possible.
1. Run the wires into an out-of-sight location as close as possible to the electromagnet. Run them inside hollow gate posts if possible.
 2. Use standard armored cable to prevent the wires from being cut between the electromagnet and the out-of-sight location.
- F. Connect the wires:
1. For 12V operation — Connect the red and white wires to +12VDC, and the black and green wires to ground.
 2. For 24V operation — Connect the red wire to +24VDC, the green wire to ground, and then tie the white and black wires together and insulate.
- IMPORTANT: Damage caused by improper connection will void warranty.**
- G. Test the unit.
- H. Insert the tamper caps into the mounting screw access holes of the electromagnet. This should be the last step, as once the tamper caps are in place, they are difficult to remove.

FIG. 1 - Parts

List of Parts

- 1 x Electromagnet
- 1 x Armature plate
- 1 x Armature screw
- 3 x Large steel washers
- 2 x Rubber washers
- 1 x Door spacer (tube)
- 1 x Sexnut bolt
- 4 x Mounting screws
- 4 x Small washers
- 4 x Tamper caps
- 2 x Guide pins
- 1 x Hex key (Allen wrench)
- 4 x Blind nuts
- 1 x Blind nut assembly set (M6x30 screw, blind nut, washer)

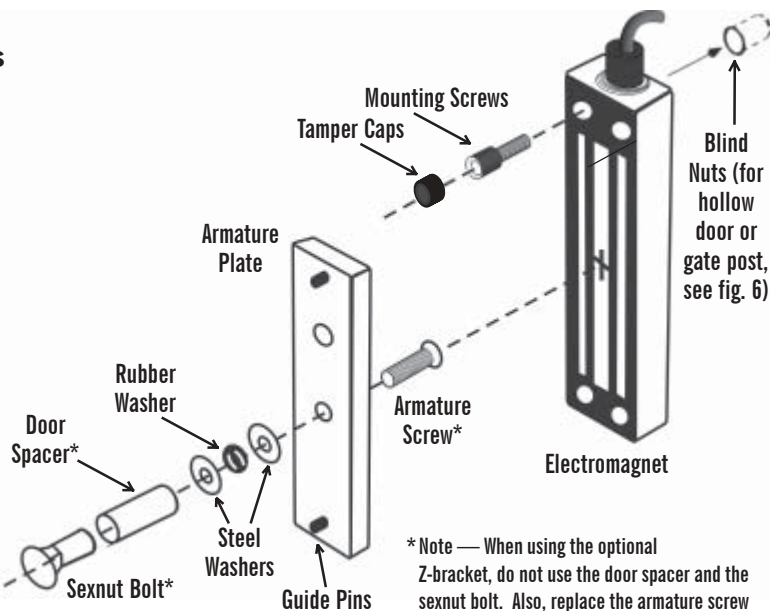

* Note — When using the optional Z-bracket, do not use the door spacer and the sexnut bolt. Also, replace the armature screw with the short armature screw included with the bracket, or cover the exposed end of the long screw with the nut.

Magnetic Gate Lock Installation Manual

FIG. 2 - Installation on a single-swing gate

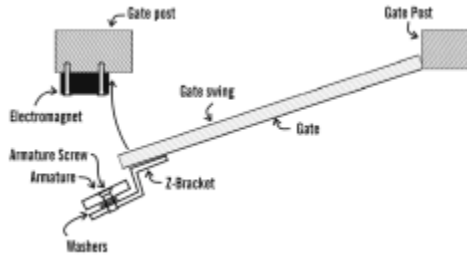

FIG. 3 - Installation on a double-swing gate

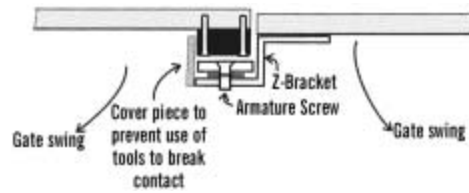

FIG. 4 - Installation on a sliding gate

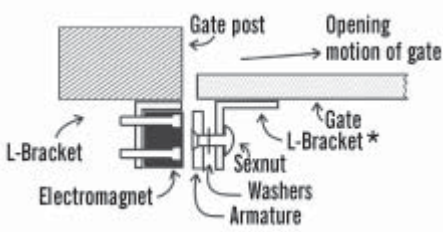

FIG. 5 - Basic Installation

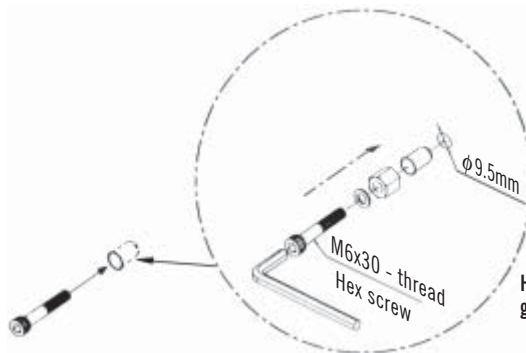
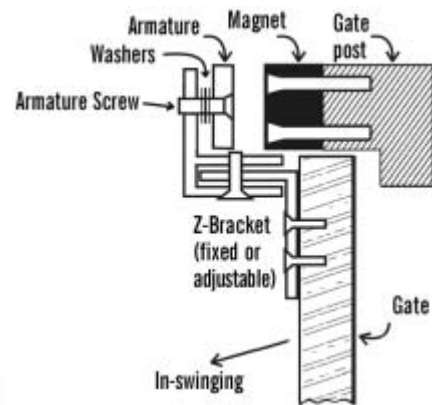
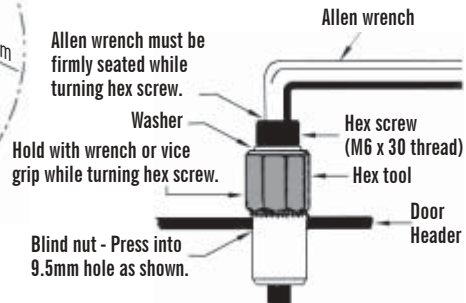

FIG. 6: Mounting the blind nuts in a hollow door or gate post



ACCESSORIES

E-942F-1300/Z - "Z" bracket for E-942FC-1300

E-942F-1300/L - "L" bracket set for E-942FC-1300