

SECO-LARM®

E-941SA-1K5Q

1,500-lb Electromagnetic Lock

Manual



Features:

- Selectable 12/24 VDC Operation
- Anodized aluminum housing material
- No residual magnetism
- MOV Surge protection
- Keyhole slot mounting plate makes installation easier
- Suitable for horizontal or vertical installation
- Complete mounting hardware included for typical installations
- "L" brackets, "Z" brackets, "U" brackets, and plate spacers available for easy mounting
- Detachable faceplate for easy wiring access

SECO-LARM 1,500-lb Electromagnetic Lock

Table of Contents:

Introduction.....	2	Installation.....	4-6
Parts List.....	2	Wiring Diagram.....	7
Specifications.....	2	Maximum Distance from Power Source to Electromagnetic Lock.....	7
Dimensions.....	2	SECO-LARM Maglock Accessories.....	7
Overview.....	3	Troubleshooting.....	8
Installation Applications.....	3	Warranty.....	8
Installation Notes.....	4		

Introduction:

The E-941SA-1K5Q 1,500-lb Single-Door Electromagnetic Lock is the ideal way to secure a door against unauthorized entry. When power is applied to the electromagnetic lock, it creates an extremely strong magnetic field. The electromagnet is strongly attracted to the steel armature plate which is mounted on the secured door. Once the electromagnet is deactivated, the secured door will function normally without any residual magnetism.

Parts List:

1x Electromagnetic lock	1x Armature plate	1x Armature screw
1x 5mm Hex wrench	1x Sexnut bolt	1x Door Spacer
2x Guide pins	2x Rubber washers	2x Steel washers
8x Long self-tapping screws	2x Short self-tapping screws	1x Mounting plate
1x Mounting template	1x Manual	

Specifications:

Holding force		1,500-lb (680kg)
Operating voltage		12/24 VDC
Current draw	12VDC	600mA@12VDC
	24VDC	300mA@24VDC
Coil resistance		46Ω ±10% per coil (see page 8)
Housing material		Anodized aluminum
Operating temperature		14°~131° F (-10°~55° C)
Dimensions	Mounting plate	11 1/4"x1 9/16"x1/4" (286x40x6 mm)
	Electromagnet	11 1/4"x1 9/16"x2 5/8" (286x40x67 mm)
	Armature plate	7 1/4"x5 5/8"x2 3/8" (185x16x60 mm)
Weight		11-lb, 1.2-oz (5kg)

Dimensions:

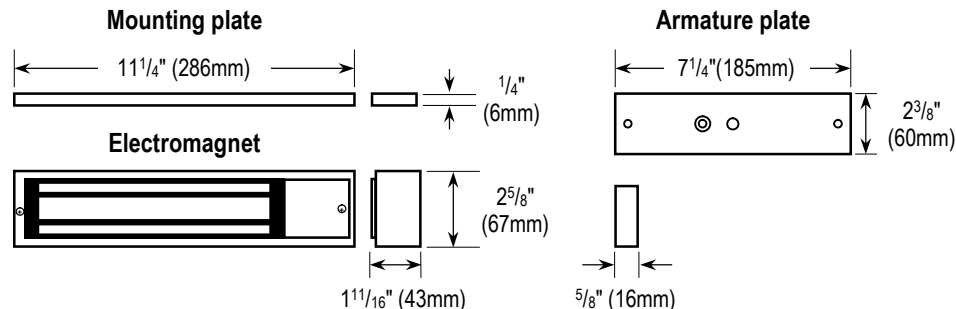

Overview:

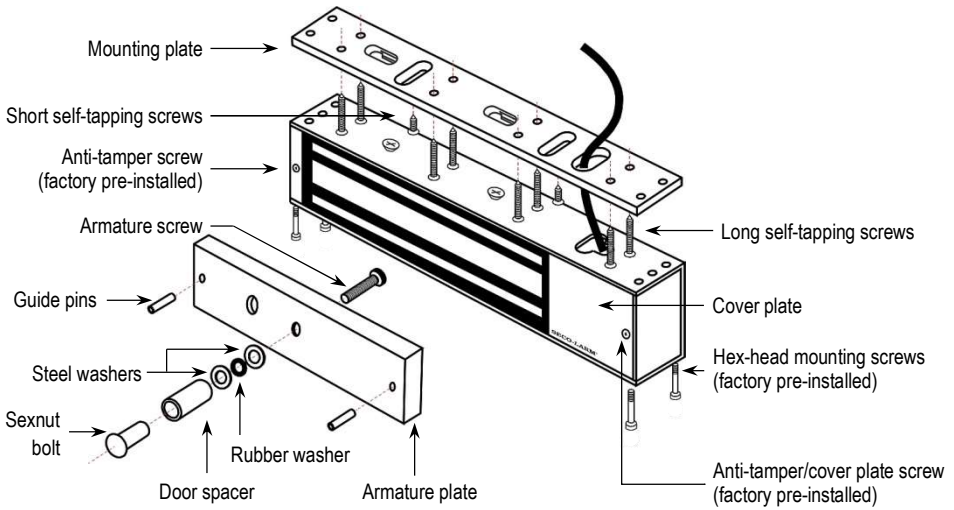

Installation Applications:

When mounting the electromagnetic lock, it may be necessary to use a "Z" bracket, 1 or 2 "L" brackets, a "U" bracket and/or plate spacers, depending on the location and the type of door and frame. Use the diagram below to help decide whether or not an optional bracket will be necessary for installation.

See page 7 for a partial list of SECO-LARM maglock accessories.

Typical Installation

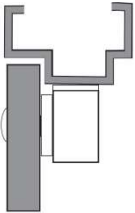
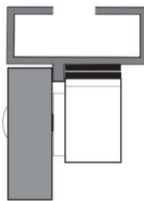
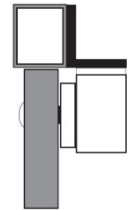

Plate Spacers



"L" Bracket



"L" Bracket and "Z" Bracket

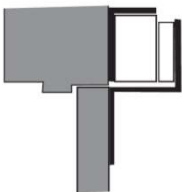

**"U" Bracket
(Typically for glass)**

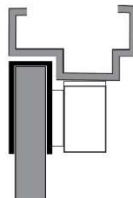

Armature-Mounting Plate

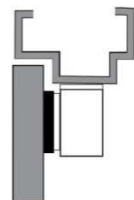

NOTE: Mounting brackets include all additional hardware required.

SECO-LARM 1,500-lb Electromagnetic Lock

Installation Notes:

1. Read this installation manual thoroughly. A clear understanding of the product and this manual will make installation much easier.
2. The electromagnetic lock is designed for indoor use ONLY.
3. The most suitable mounting location for the electromagnetic lock may require the use of additional SECO-LARM accessories such as "Z" brackets, "L" brackets, "U" brackets and/or plate spacers. See the diagram on pg. 3 to decide if a particular application requires any mounting accessories. See pg. 7 for a partial list of SECO-LARM maglock accessories.
4. Do not run power wires and signal wires in the same conduit as this may cause interference.
5. Do not install a diode in parallel with the electromagnetic lock as this may cause a delay when releasing the door as well as cause residual magnetism.
6. The best location to install the electromagnetic lock is on the inside of the door that is being secured with the wiring concealed in the frame to prevent tampering.

Installation:

1. Fold the included mounting template along the dotted center line to form a 90-degree angle (see Fig. 1).
2. Close the door. Find a mounting location on the door frame near the upper free-moving corner of the door, or as close as possible to the upper corner of the door frame opposite the hinges (see Fig. 2).
3. Place the mounting template against the door and frame. Mark where the holes are to be drilled (see Fig. 3).
4. Drill two holes in the frame and three holes in the door as shown on the template (see Fig. 4).
5. Use a hammer to lightly tap the guide pins into the guide pin holes on the armature plate (see Fig. 5).

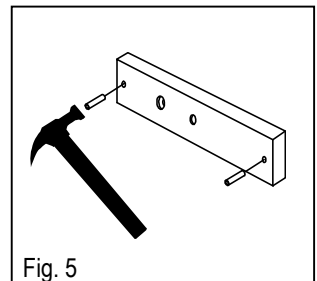
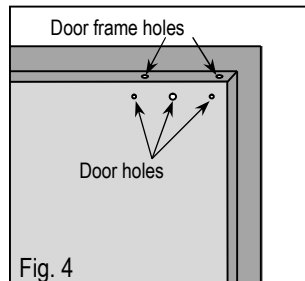
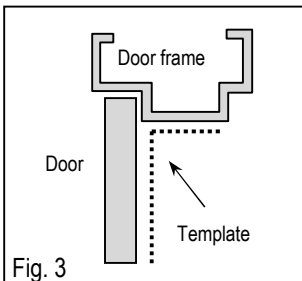
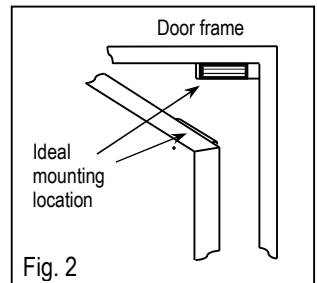
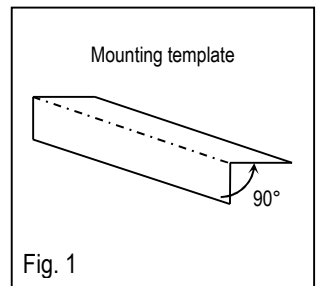

Installation (Continued):

6. Depending on the type of door being protected, drill holes according to the diagrams in Fig. 6.

Fig. 6

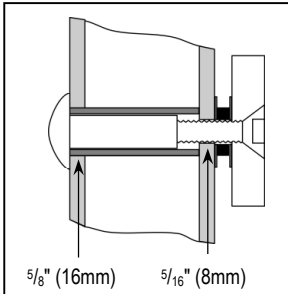

Hollow Metal Door

Drill a $\frac{5}{16}$ " (8mm) dia. hole through the armature-plate side of the door for the armature screw. Then drill a $\frac{5}{8}$ " (16mm) dia. hole for the sexnut bolt on the opposite side of the door.

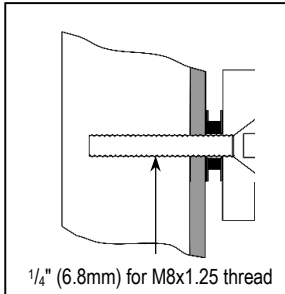

Reinforced Door

Drill a $\frac{1}{4}$ " (6.8mm) dia. and 1" (25mm) deep hole, tap for M8x1.25 thread.

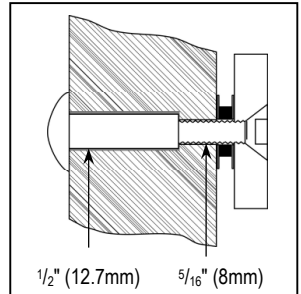

Solid Core Door

Drill a $\frac{5}{16}$ " (8mm) dia. hole in the door for the armature screw, and drill a $\frac{1}{2}$ " (12.7mm) hole 1" (25mm) in depth for the sexnut bolt.

7. Mount the armature plate to the door using the included sexnut bolt and door spacer, along with one rubber washer sandwiched between two steel washers. This allows the plate to pivot around the screw to compensate for door misalignment (see Fig. 7).

8. Tighten the armature screw enough so that the armature plate can withstand a break-in attempt, but loose enough so that the armature plate can pivot slightly. Make sure the anti-spin guide pins are in the two guide pin holes (see Fig. 8).

Tip: Use a thread-locking compound on the armature screw to ensure a long-lasting installation.

9. Remove the two anti-tamper screws from the electromagnet and the cover plate. (see Fig. 9). Remove the four hex head mounting screws to unmount the mounting plate from the electromagnet.

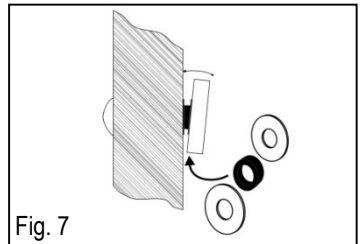

Fig. 7

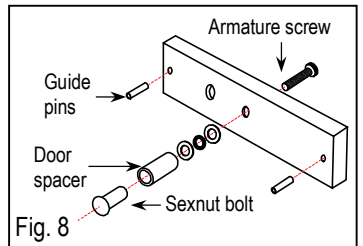

Fig. 8

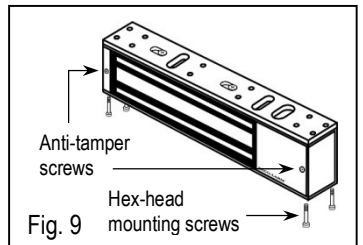

Fig. 9

SECO-LARM 1,500-lb Electromagnetic Lock

Installation (Continued):

10. After determining the correct location, install the two short self-tapping screws through the mounting plate oblong slots but do not tighten them. Adjust the mounting plate position and confirm the position by holding the magnet in place. Once satisfied with the position, tighten the screws (see Figs. 10 and 11).
11. Once the position of the mounting plate is correct, screw in and install the eight long self-tapping screws (see Fig. 12).
12. Drill the cable access hole. Run the power leads through the cable access hole in the mounting plate and through the hole in the door frame (see Fig. 13).
13. Run the power leads through the large cable access hole of the electromagnet (see Fig. 14).
14. Mount the electromagnet through the keyhole slots and align the electromagnet with the mounting plate so the electromagnet ends are flush with the ends of the mounting plate. Use the hex wrench to screw the hex-head mounting screws (that you removed in step 9) through the bottom of the electromagnet into the mounting bracket (see Fig. 15).
15. Cut the wires so they are long enough to connect with the terminal block. Set the voltage using the selection jumpers based on your input voltage (see "Wiring Diagram" on pg. 7).

NOTE: Failure to correctly set the input voltage may cause damage to the lock.

NOTE: Connect switching devices like push-to-exit switches between the power source and the positive terminal on the lock. Connecting switching devices to the negative terminal may cause residual magnetism and a delay in unlocking.

16. Connect the power wires according to the "Wiring Diagram" on pg. 7. Test the unit. Replace the cover plate and the anti-tamper screws.

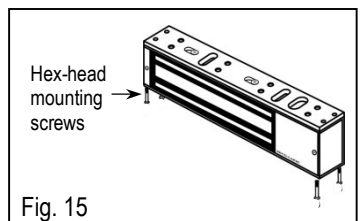
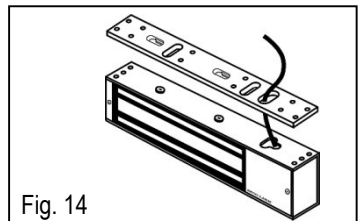
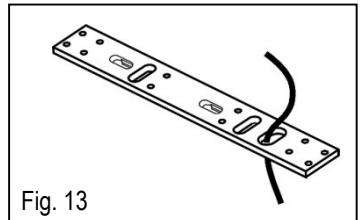
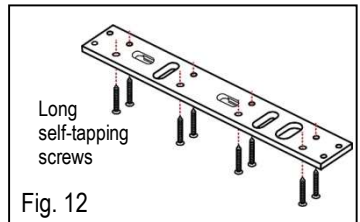
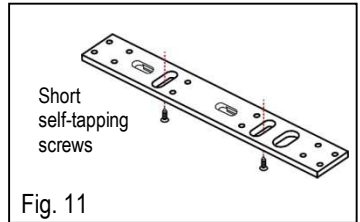
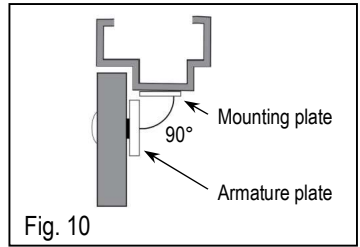

Wiring Diagram:

Voltage Selection Jumpers

12VDC Operation:

To select 12VDC operation, position two jumpers on all four pins.



24VDC Operation:

To select 24VDC operation, position a single jumper over the two center pins.

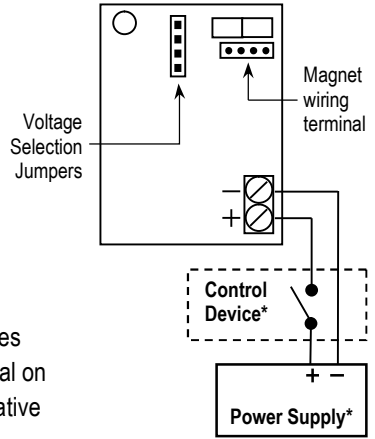

***NOTE:** Connect switching devices like push-to-exit switches between the power source and the positive terminal on the lock. Connecting switching devices to the negative terminal may cause

Maximum Distance from Power Source to Electromagnetic Lock:

12VDC Minimum Wire Gauge:

Wire Length	25ft	50ft	75ft	100ft	150ft	200ft	250ft	300ft	400ft	500ft	1000ft
Wire Gauge @ 600mA	20	18	18	18	16	14	14	12	10	--	--

24VDC Minimum Wire Gauge:

Wire Length	25ft	50ft	75ft	100ft	150ft	200ft	250ft	300ft	400ft	500ft	1000ft
Wire Gauge @ 300mA	24	24	22	20	18	18	16	16	14	14	14

Optional SECO-LARM Electromagnetic Lock Accessories:

"L" Bracket



E-941S-1K5/LQ

"L" & "Z" Brackets



E-941S-1K5/ZQ

"U" Brackets



E-941S-1K2/UQ

Plate spacer



E-941S-1K5/PQ

Also Available from SECO-LARM®:

Access Control Power Supply



EAP-5D1Q

Digital Access Keypads



SK-2323-SDQ

Complete Line of Electromagnetic Locks



E-941SA-1200

Voltage Converters or Boosters



ST-LA110-TTQ

Wired or Wireless RTE Plates



SD-7202GC-PEQ

SECO-LARM 1,500-lb Electromagnetic Lock

Troubleshooting:

- | | |
|-------------------------------------------|------------------------------------------------------------------------------------------------------------------------------------------------------------------------------------------------------------------------------------------------------------------------------------------------------------------------------------------------------------------------------------------------------------------------------------------------------------------------------------------------------------------------------------------------|
| Door does not lock | <ul style="list-style-type: none">• Check that the wires are securely tightened to the terminal block• Check that the power supply is connected and operating• Use a multimeter to check the resistance of coils inside the lock; see below• Make sure the rubber washer is installed and undamaged |
| Door locks, but can easily be forced open | <ul style="list-style-type: none">• Make sure the electromagnet and armature plate are properly aligned• Make sure the contact surfaces of the electromagnet and armature plate are clean and free from rust• Check the power leads with a multimeter to see if 12 or 24 VDC is present• Use a multimeter to check the resistance of coils inside the lock; see below• Make sure the rubber washer is installed and undamaged• Check voltage selection jumpers for correct settings |
| Delay in door releasing | <ul style="list-style-type: none">• The electromagnet is fitted with a metal oxide varistor to prevent interference, so do not install a second diode• Check that the control device is installed to the positive terminal |

If the Electromagnet has low or no holding force, check the resistance of the coils by performing the following steps:

1. Remove the faceplate from the lock.
2. Disconnect the wire harness from the circuit board.
3. Using a multimeter, measure the resistance across:
Red/Green wires, and the Black/White wires.
4. Each coil should test at $46\Omega \pm 10\%$.
5. If one or both of the coils show an open, short, or incorrect resistance, replace the electromagnet.

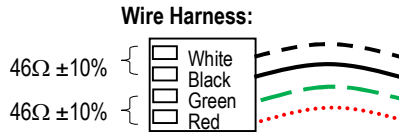

WARRANTY: This SECO-LARM product is warranted against defects in material and workmanship while used in normal service for one (1) year from the date of sale to the original customer. SECO-LARM's obligation is limited to the repair or replacement of any defective part if the unit is returned, transportation prepaid, to SECO-LARM. This Warranty is void if damage is caused by or attributed to acts of God, physical or electrical misuse or abuse, neglect, repair or alteration, improper or abnormal usage, or faulty installation, or if for any other reason SECO-LARM determines that such equipment is not operating properly as a result of causes other than defects in material and workmanship. The sole obligation of SECO-LARM and the purchaser's exclusive remedy, shall be limited to the replacement or repair only, at SECO-LARM's option. In no event shall SECO-LARM be liable for any special, collateral, incidental, or consequential personal or property damage of any kind to the purchaser or anyone else.

NOTICE: The SECO-LARM policy is one of continual development and improvement. For that reason, SECO-LARM reserves the right to change specifications without notice. SECO-LARM is also not responsible for misprints. All trademarks are the property of SECO-LARM U.S.A., Inc. or their respective owners. Copyright © 2021 SECO-LARM U.S.A., Inc. All rights reserved.

SECO-LARM® U.S.A., Inc.

16842 Millikan Avenue, Irvine, CA 92606
Phone: (949) 261-2999 | (800) 662-0800

Website: www.seco-larm.com
Email: sales@seco-larm.com

 PITVV2

MI_E-941SA-1K5Q_210219.docx