

### Magnetic Door Holders

**DH-171SQ** Flush-mount

**DH-151SQ** Surface-mount

The UL Listed SECO-LARM Magnetic Door Holders are designed for virtually any remote door release applications, whether residential or commercial. Fail-safe operation, tri-volt coils, and adjustable armature plate allows for easy and flexible installation.

#### Features

- For use with door closers to control the release and closing of residential, commercial, and public area doors
- Adjustable armature (DH-100A-01SQ, included) reduces installation time and adjusts to door alignment changes
- Surface- or flush-mount models available
- Fail-safe operation
- Low profile design
- Holding force – 33-lb (15kg)
- 3 voltages: 12/24 VAC/VDC, and 120VAC
- Cast aluminum faceplate
- No residual magnetism for easy release
- Built-in voltage spike suppressor
- Optional extension bars available: 3/4", 1", 4", 7" (19mm, 25mm, 102mm, 178mm)
- Use with SECO-LARM door closers SD-C121-S, SD-C131-SQ, SD-C101-SGQ, or SD-C101-SBAQ

#### Specifications

Model	DH-151SQ	DH-171Q
Installation	Surface-mount	Flush-mount
Operating voltage	12/24 VAC/VDC, 120VAC	
Current draw (max.)	52mA@12VAC, 60mA@12VDC	
	27mA@24VAC, 31mA@24VDC	
	24mA@120VAC	
Holding force	33-lb (15kg)	
Dimensions	Magnet	2 <sup>3</sup> / <sub>4</sub> "x4 <sup>9</sup> / <sub>16</sub> "x3" (70x116.5x76 mm)
	Armature	2 <sup>9</sup> / <sub>16</sub> "x2 <sup>9</sup> / <sub>16</sub> "x 1 <sup>9</sup> / <sub>16</sub> " (65x65x40 mm)
Magnet box weight	1-lb 6.4-oz (635g)	1-lb 1.5-oz (496g)
Door armature weight	8.1-oz (230g)	



#### Dimensions (magnet only)

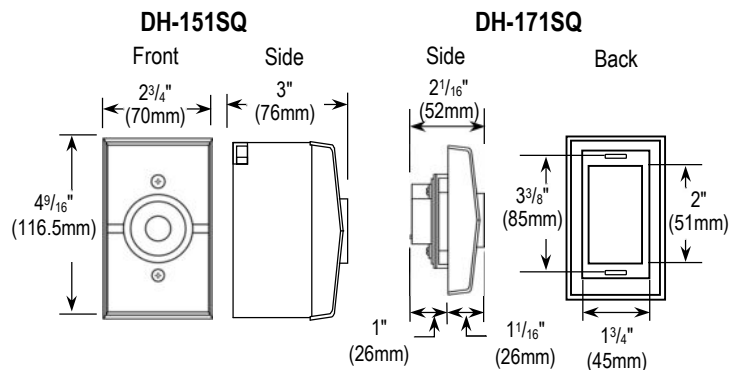

#### SECO-LARM® U.S.A., Inc.

16842 Millikan Avenue, Irvine, CA 92606

Phone: (949) 261-2999 | (800) 662-0800 Fax: (949) 261-7326

Website: www.seco-larm.com Email: sales@seco-larm.com



Copyright © 2022 SECO-LARM U.S.A., Inc. All rights reserved. All trademarks are the property of SECO-LARM U.S.A., Inc. or their respective owners. The SECO-LARM policy is one of continual development. For that reason, SECO-LARM reserves the right to change prices and specifications without notice. SECO-LARM is not responsible for misprints. SECO-LARM® ENFORCER® CRIMEBUSTER® CBA® SLI®

### Magnetic Door Holders

**DH-171SQ** Flush-mount

**DH-151SQ** Surface-mount

The UL Listed SECO-LARM Magnetic Door Holders are designed for virtually any remote door release applications, whether residential or commercial. Fail-safe operation, tri-volt coils, and adjustable armature plate allows for easy and flexible installation.

#### Features

- For use with door closers to control the release and closing of residential, commercial, and public area doors
- Adjustable armature (DH-100A-01SQ, included) reduces installation time and adjusts to door alignment changes
- Surface- or flush-mount models available
- Fail-safe operation
- Low profile design
- Holding force – 33-lb (15kg)
- 3 voltages: 12/24 VAC/VDC, and 120VAC
- Cast aluminum faceplate
- No residual magnetism for easy release
- Built-in voltage spike suppressor
- Optional extension bars available: 3/4", 1", 4", 7" (19mm, 25mm, 102mm, 178mm)
- Use with SECO-LARM door closers SD-C121-S, SD-C131-SQ, SD-C101-SGQ, or SD-C101-SBAQ

#### Specifications

Model	DH-151SQ	DH-171Q
Installation	Surface-mount	Flush-mount
Operating voltage	12/24 VAC/VDC, 120VAC	
Current draw (max.)	52mA@12VAC, 60mA@12VDC	
	27mA@24VAC, 31mA@24VDC	
	24mA@120VAC	
Holding force	33-lb (15kg)	
Dimensions	Magnet	2 <sup>3</sup> / <sub>4</sub> "x4 <sup>9</sup> / <sub>16</sub> "x3" (70x116.5x76 mm)
	Armature	2 <sup>3</sup> / <sub>4</sub> "x4 <sup>9</sup> / <sub>16</sub> "x2 <sup>1</sup> / <sub>16</sub> " (70x116.5x52 mm)
Magnet box weight	1-lb 6.4-oz (635g)	1-lb 1.5-oz (496g)
Door armature weight	8.1-oz (230g)	



#### Dimensions (magnet only)

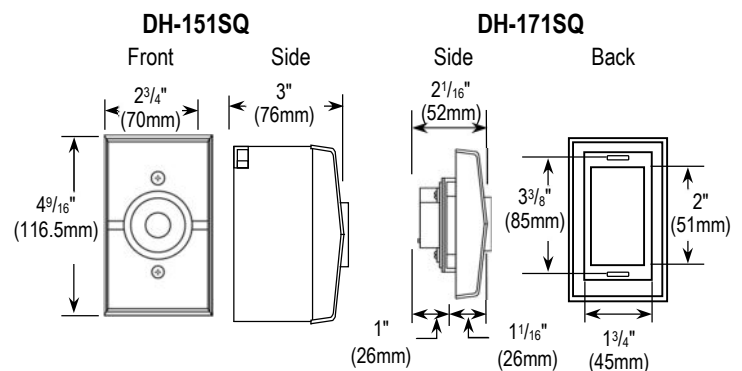

#### SECO-LARM® U.S.A., Inc.

16842 Millikan Avenue, Irvine, CA 92606

Phone: (949) 261-2999 | (800) 662-0800 Fax: (949) 261-7326

Website: www.seco-larm.com Email: sales@seco-larm.com



Copyright © 2022 SECO-LARM U.S.A., Inc. Todos los derechos reservados. Todas las marcas comerciales son propiedad de SECO-LARM U.S.A., Inc. o sus respectivos propietarios. La póliza de SECO-LARM es de desarrollo y mejora continua. Por esa razón, SECO-LARM se reserva el derecho de cambiar las especificaciones y los precios sin previo aviso. SECO-LARM tampoco es responsable de errores de impresión.

SECO-LARM® ENFORCER® CRIMEBUSTER® CBA® SLI®

PI\_DH-1x1SQ\_220629.docx