



### What's in the Box:

1x SK-B241-PQ ENFORCER Bluetooth® Mullion Keypad with Reader

4x Mounting screws    4x Plastic wall anchors    12x Wire crimps    1x Diode    1x Varistor  
1x Security screw bit    1x Quick Installation/Setup Guide    1x Additional Information

### Specifications:

Operating voltage	9-25 VDC
Current draw	Standby 50mA@12VDC, 28mA@24VDC Active (max.) 58mA@12VDC, 33mA@24VDC
Outputs	Form C 2.0A@30VDC Tamper alarm 100mA@30VDC (solid state N.C.)
Egress input	N.O. Ground
Door sensor input	N.C. Ground
Proximity reader	EM 125kHz
IP Rating	IP65 Weather-resistant
Enclosure material	Zinc alloy
Operating humidity	0-95%, non-condensing
Operating temperature	-4°~122° F (-20°~50° C)
Dimensions	1 3/4"x6"x7 1/8" (45x152x23 mm)
Weight	15.8-oz (447g)

### Sample Wiring Diagram:

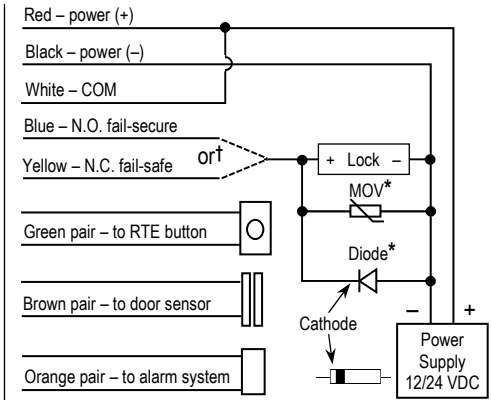

### IMPORTANT NOTES:

\*To protect the relay, you must install the enclosed diode—with the cathode (striped end) toward the positive side—for DC powered locks and install the varistor (MOV) for AC powered locks and for electromagnetic locks *unless your lock has a diode/MOV built in*. Failure to use these as directed will void the warranty.

†Use the blue wire for fail-secure applications and the yellow wire for fail-safe applications. Use electrical tape to insulate the end of any unused wire.

# ENFORCER Bluetooth® Mullion Keypad with Reader

## Installation and Mounting:

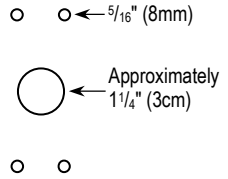
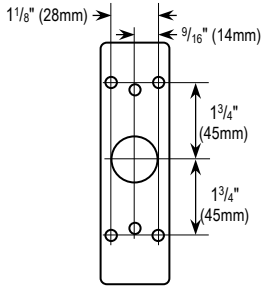

### Remove Base

Using the security bit, remove the screw and housing base.

### Mark Holes for Drilling

Using the base, mark mounting and wiring holes.

### Drill Holes

Drill the five holes. The wiring hole should be about  $\varnothing 1\frac{1}{4}$ " ( $\varnothing 3$ cm).

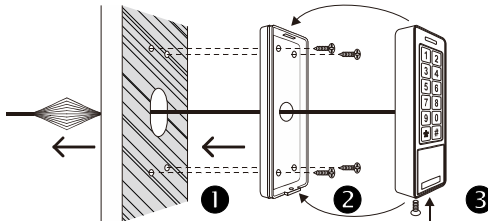

### 1. Feed Wires into Wall

Connect wires and push through the hole in the wall, taking care not to loosen any connectors.

### 2. Mount Base to Wall

Mount the base to the wall using the supplied screws and wall anchors or other screws.

### 3. Mount Keypad to Base

Slide the device to engage the tab on the top of the base, and secure with the security screw.

The Bluetooth® word mark and logos are registered trademarks owned by Bluetooth SIG, Inc. and any use of such marks by SECO-LARM is under license. Other trademarks and trade names are those of their respective owners.

**California Proposition 65 Warning:** These products may contain chemicals which are known to the State of California to cause cancer and birth defects or other reproductive harm. For more information, go to [www.P65Warnings.ca.gov](http://www.P65Warnings.ca.gov).

**IMPORTANT WARNING:** For a weather-resistant installation, ensure that the housing back is installed tightly against the wall and properly sealed. Incorrect mounting may lead to exposure to rain or moisture in the enclosure which could cause a dangerous electric shock, damage the device, and void the warranty. Users and installers are responsible for ensuring that this product is properly installed and sealed.

**IMPORTANT:** Users and installers of this product are responsible for ensuring that the installation and configuration of this product complies with all national, state, and local laws and codes related to locking and egress devices. SECO-LARM will not be held responsible for the use of this product in violation of any current laws or codes.

#### FCC/IC COMPLIANCE STATEMENT FOR BLUETOOTH MODULE

FCC ID: K7TRB8762

IC ID: 2377ARB8762

THIS DEVICE COMPLIES WITH PART 15 OF THE FCC RULES. OPERATION IS SUBJECT TO THE FOLLOWING TWO CONDITIONS: (1) THIS DEVICE MAY NOT CAUSE HARMFUL INTERFERENCE AND (2) THIS DEVICE MUST ACCEPT ANY INTERFERENCE RECEIVED, INCLUDING INTERFERENCE THAT MAY CAUSE UNDESIRABLE OPERATION.

Notice: The changes or modifications not expressly approved by the party responsible for compliance could void the user's authority to operate the equipment.

**IMPORTANT NOTE:** To comply with the FCC RF exposure compliance requirements, no change to the antenna or the device is permitted. Any change to the antenna or the device could result in the device exceeding the RF exposure requirements and void user's authority to operate the device.

This device complies with Industry Canada licence-exempt RSS standard(s). Operation is subject to the following two conditions: (1) this device may not cause interference, and (2) this device must accept any interference, including interference that may cause undesired operation of the device.

Le présent appareil est conforme aux CNR d'Industrie Canada applicables aux appareils radio exempts de licence. L'exploitation est autorisée aux deux conditions suivantes: (1) l'appareil ne doit pas produire de brouillage, et (2) l'utilisateur de l'appareil doit accepter tout brouillage radioélectrique subi, même si le brouillage est susceptible d'en compromettre le fonctionnement.

**WARRANTY:** This SECO-LARM product is warranted against defects in material and workmanship while used in normal service for one (1) year from the date of sale to the original customer. SECO-LARM's obligation is limited to the repair or replacement of any defective part if the unit is returned, transportation prepaid, to SECO-LARM. This Warranty is void if damage is caused by or attributed to acts of God, physical or electrical misuse or abuse, neglect, repair or alteration, improper or abnormal usage, or faulty installation, or if for any other reason SECO-LARM determines that such equipment is not operating properly as a result of causes other than defects in material and workmanship. The sole obligation of SECO-LARM and the purchaser's exclusive remedy, shall be limited to the replacement or repair only, at SECO-LARM's option. In no event shall SECO-LARM be liable for any special, collateral, incidental, or consequential personal or property damage of any kind to the purchaser or anyone else.

**NOTICE:** The SECO-LARM policy is one of continual development and improvement. For that reason, SECO-LARM reserves the right to change specifications without notice. SECO-LARM is also not responsible for misprints. All trademarks are the property of SECO-LARM U.S.A., Inc. or their respective owners. Copyright © 2022 SECO-LARM U.S.A., Inc. All rights reserved.

## SECO-LARM® U.S.A., Inc.

16842 Millikan Avenue, Irvine, CA 92606  
Phone: (949) 261-2999 | (800) 662-0800

Website: [www.seco-larm.com](http://www.seco-larm.com)  
Email: [sales@seco-larm.com](mailto:sales@seco-larm.com)



MA\_SK-B241-PQ\_220309.docx