

## Low-Noise CCTV Power Supply

### PC-L1620-PQ

16 Outputs, Total supply current: 20A, Input current: 4A

The ENFORCER Low-Noise Switching CCTV Power Supply is designed for applications where noise is a problem due to inadequate wiring. Each output's voltage is individually adjustable to compensate for voltage drop. Each output is independently isolated and grounded with integrated noise filtering to help reduce noise interference with 4K (8MP) HD cameras, non-PoE IP cameras, and analog security cameras.

### Features

- Each output's voltage individually adjustable to compensate for voltage drop
- Low-noise design for all CCTV applications where filtered power is needed, such as 4K (8MP) HD CCTV cameras, non-PoE IP cameras, and analog cameras
- 110/220 VAC input with 6kV surge protection
- Outputs independently grounded with integrated noise filter for better noise reduction
- Outputs individually isolated and individually fused (2A PTC)
- Individual output status LEDs
- Heavy-duty steel case with cover and cam lock
- Built-in short circuit and overheat protection

### Specifications

Operating voltage	110/220 VAC (50/60 Hz)
Outputs	16
Total supply current	20A
Max. current per output	1.25A
Output fuse	2A PTC (Per-channel)
Output voltage	12VDC ±5%
Efficiency	80%
LED Indicators	Individual, per output, red indicates powered
Operating humidity	95% non-condensing
Operating temperature	32°~104° F (0°~40° C)
Dimensions	8"x9 <sup>3</sup> / <sub>16</sub> "x3 <sup>15</sup> / <sub>16</sub> " (204x250x100 mm)
Weight	6-lb (2.71kg)



Individually Grounded & Isolated

Supports 4K (8MP) CCTV

Individually Adjustable Voltage

### Output Isolation / Independent Voltage

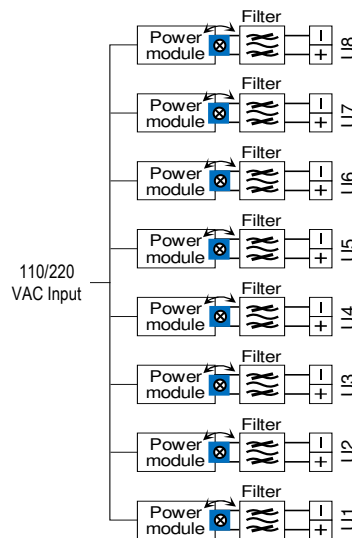

Each output's voltage is independently adjustable via individual potentiometers.



Each output is completely isolated and independently grounded, with integrated noise filtering.

**NOTE:** Only 8 outputs shown here for simplicity.

### SECO-LARM® U.S.A., Inc.

16842 Millikan Avenue, Irvine, CA 92606

Phone: (949) 261-2999 | (800) 662-0800 Fax: (949) 261-7326

Website: www.seco-larm.com Email: sales@seco-larm.com



Copyright © 2023 SECO-LARM U.S.A., Inc. All rights reserved.

All trademarks are the property of SECO-LARM U.S.A., Inc. or their respective owners.

The SECO-LARM policy is one of continual development. For that reason, SECO-LARM reserves the right to change prices and specifications without notice. SECO-LARM is not responsible for misprints.

**SECO-LARM® ENFORCER® CRIMEBUSTER® CBA® SLI®**

PI\_PC-L1620-PQ\_230620.docx