

## Sealed-Housing Weatherproof Keypads

**SK-1323-SDQ** *Stand-Alone Keypad*

**SK-1323-SPQ** *Stand-Alone Keypad with Built-In Proximity Reader*

### Features

- 1,010 Users (Output #1: 1,000 users, Output #2: 10 users).
- 2 Form C relay outputs.
- Each relay has programmable output time from 1~99 seconds or toggle.
- Output #2 can be programmed for use with a doorbell.
- 2 Egress inputs and 1 door sensor input.
- Backlit keys for easy nighttime use.
- 2 Multi-colored status LEDs
- All features are programmed directly from the keypad—no need for an external programmer.
- EEPROM protects programmed information in case of power loss.
- Optical tamper sensor for added security.
- Circuitry is potted with epoxy for outdoor use.
- Weatherproof (IP65).
- Rugged aluminum construction.

### SK-1323-SPQ only

- Built-in 125kHz proximity reader
- 3 Programmable access modes for Output #1:  
Card Only, Card or Code, and Card with Code
- Output #2 may have either a card or a code programmed for each user.



SK-1323-SPQ shown

### Specifications

Model	SK-1323-SDQ	SK-1323-SPQ
Operating voltage	12-24 VAC/VDC	
Current draw	Standby	40mA@12VDC
	Active	70mA@12VDC
Relay outputs	Output #1	1A@30VDC, Form C, NO/NC/COM
	Output #2	1A@30VDC, Form C, NO/NC/COM
Egress inputs	Input #1	N.O. ground
	Input #2	N.O. ground
Door sensor input	N.C. ground	
Tamper sensor	Optical	
Operating temperature	-4°~122° F (-20°~50° C)	
Keypad LED life	60,000 hours (over 6.8 years)	
Weight	1-lb 2-oz (510g)	
Proximity reader frequency	N/A	125kHz
Proximity reader distance	N/A	1 <sup>15</sup> / <sub>16</sub> " (5cm)

### Dimensions

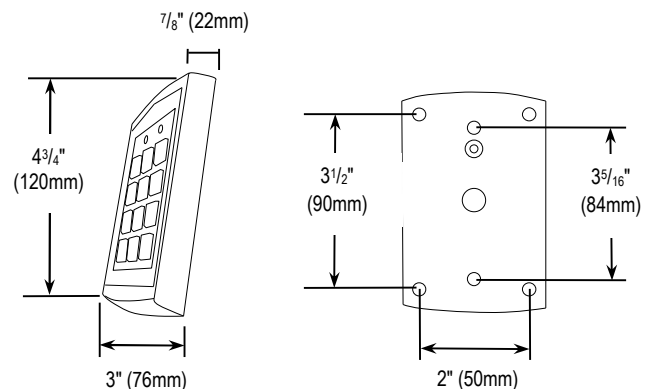

### SECO-LARM® U.S.A., Inc.

16842 Millikan Avenue, Irvine, CA 92606

Phone: (949) 261-2999 | (800) 662-0800 Fax: (949) 261-7326

Website: [www.seco-larm.com](http://www.seco-larm.com) Email: [sales@seco-larm.com](mailto:sales@seco-larm.com)



Copyright © 2021 SECO-LARM U.S.A., Inc. All rights reserved.  
All trademarks are the property of SECO-LARM U.S.A., Inc. or their respective owners.  
The SECO-LARM policy is one of continual development. For that reason, SECO-LARM reserves the right to change prices and specifications without notice. SECO-LARM is not responsible for misprints.

**SECO-LARM® ENFORCER® CRIMEBUSTER® CBA® SLI®**

PI\_SK-1323-SxQ\_230711.docx

**Wiring Diagram**

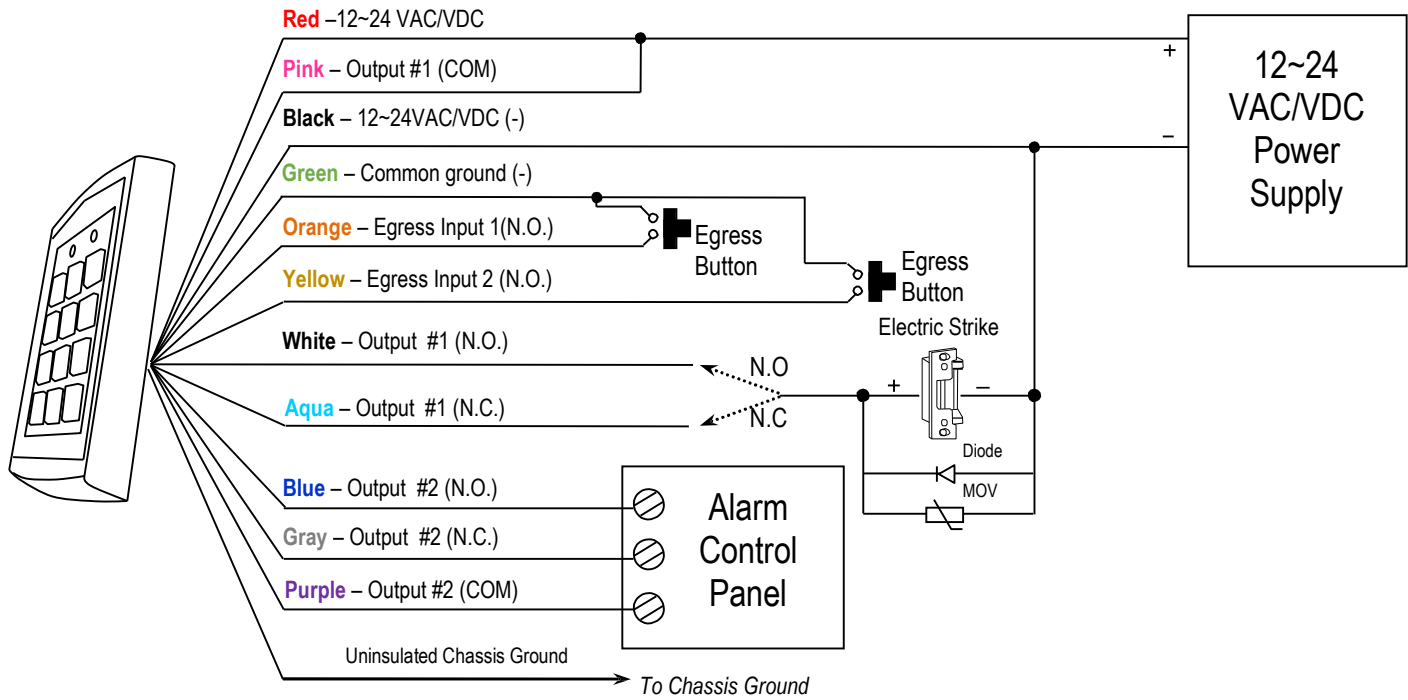

**Status LEDs**

Left LED	Right LED	Keypad Status
OFF	Green	Power ON
OFF	Orange	Programming Mode
Green	Orange flashing	Waiting to program code/card* (card+code access mode)
Red	Orange flashing	Code/card* already present
Green	Green	Relay 1 activated
Red	Green	Relay 2 activated
Orange	Green	Relay 1 and 2 both activated
Orange	Orange	Restoring factory defaults
Green/Yellow flashing	Green	Waiting for code/card entry* (card+code access mode)
OFF	OFF	Power OFF / Clearing user codes

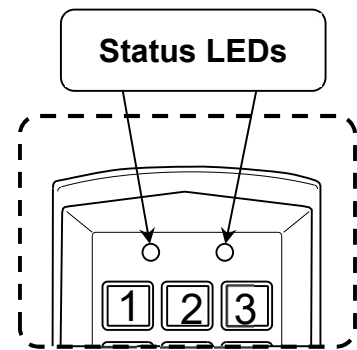

\*Card operation with SK-1323-SPQ only.