

## Unmanaged PoE Switches

### Installation Manual



NS-516UT-GAQ shown



Model	Ethernet	Ports	Bandwidth	VLAN	Power
NS-104UT-MAQ	10/100BASE-T	4 Downlink, 2 uplink	1.2Gbps	Yes	60W Adapter
NS-504UT-GAQ	10/100/1000BASE-T	4 Downlink, 1 uplink, 1 SFP	12Gbps	No	62W Built-in
NS-508UT-GAQ	10/100/1000BASE-T	8 Downlink, 2 uplink	20Gbps	No	120W Built-in
NS-516UT-GAQ	10/100/1000BASE-T	16 Downlink, 2 uplink, 2 SFP	40Gbps	Yes	250W Built-in
NS-524UT-GAQ	10/100/1000BASE-T	24 Downlink, 2 uplink, 2 SFP	56Gbps	Yes	370W Built-in

ENFORCER Unmanaged PoE Switches provide Ethernet and power to PoE devices such as IP cameras, IP access control, IP speakers/intercoms, IP telephony, etc. Fast packet forwarding capability and extra backplane bandwidth ensure clear images at fast transmission speeds for video, making them well-suited for HD IP CCTV installations.

- Provides both Ethernet data and power to multiple PoE devices including IP cameras, IP access, IP speakers/intercoms, VOIP, etc.
- Specially designed for video transmission with fast packet forwarding capability for clear images and smooth transmission
- Easy plug-and-play installation
- Supports up to 10/100/1000BASE-T\*
- IEEE 802.3x flow control

\*NS-104UT-MAQ supports 10/100BASE-T only

**Parts List**

1x **PoE Switch**                      1x **Power adapter\***                      1x **AC Power cord**                      1x **Manual**  
 \*NS-104UT-MAQ only

**Specifications**

Model	NS-104UT-MAQ	NS-504UT-GAQ	NS-508UT-GAQ	NS-516UT-GAQ	NS-524UT-GAQ
<b>Operating voltage</b>	48~57 VDC†	100~240 VAC			
<b>Power consumption</b>	<5W	<5W	<10W	<15W	<20W
<b>Ports</b>	4 Downlink, 2 uplink	4 Downlink, 1 uplink, 1 SFP	8 Downlink, 2 uplink	16 Downlink, 2 uplink, 2 SFP	24 Downlink, 2 uplink, 2 SFP
<b>Ethernet speed</b>	10/100Mbps (uplink, 100Mbps)	10/100/1000Mbps (uplink, 1000Mbps)			
<b>Ethernet standard</b>	IEEE 802.3, IEEE 802.3u, IEEE 802.3af, IEEE 802.3at, IEEE 802.3x	IEEE 802.3, IEEE 802.3u, IEEE 802.3ab, IEEE 802.3af, IEEE 802.3at, IEEE 802.3x, IEEE 802.3z	IEEE 802.3, IEEE 802.3u, IEEE 802.3af, IEEE 802.3at, IEEE 802.3x, IEEE 802.3ab, IEEE 802.3z	IEEE 802.3, IEEE 802.3i, IEEE 802.3u, IEEE 802.3ab, IEEE 802.3z, IEEE 802.3af, IEEE 802.3at, IEEE 802.3x	
<b>Transmission distance</b>	328ft (100m) <sup>‡§</sup>				
<b>PoE capacity</b>	55W	60W	120W	250W	370W
<b>Switching capacity</b>	1.2Gbps	12Gbps	20Gbps	40Gbps	56Gbps
<b>Transfer rate</b>	10Mbps	14,880pps			
	100Mbps	148,800pps			
	1000Mbps	N/A	1,488,000pps		
<b>MAC Address table</b>	1K	2K	4K	8K	
<b>LED Indicators</b>	Connection/transmission and PoE for each port, power				
<b>Operating humidity</b>	0~85% non-condensing			0~90% non-condensing	
<b>Operating temperature</b>	14°~122° F (-10°~40° C)				
<b>Dimensions</b>	4"x7 <sup>1</sup> / <sub>8</sub> "x2 <sup>15</sup> / <sub>16</sub> " (102x22x75 mm)	6 <sup>5</sup> / <sub>8</sub> "x1 <sup>1</sup> / <sub>4</sub> "x3 <sup>11</sup> / <sub>16</sub> " (168x32x94 mm)	7 <sup>7</sup> / <sub>8</sub> "x2 <sup>3</sup> / <sub>4</sub> "x4 <sup>5</sup> / <sub>8</sub> " (200x44x118 mm)	12 <sup>5</sup> / <sub>8</sub> "x1 <sup>3</sup> / <sub>4</sub> "x8 <sup>1</sup> / <sub>8</sub> " (320x44x207 mm)	
<b>Weight</b>	6.8-oz (194g)	1-lb 5-oz (480g)	1-lb 12.4-oz (806g)	4-lb 8-oz (2.06kg)	

†Power adapter included    ‡ Distance depends on Ethernet cables used. Cat5e/6 recommended

§656ft (200m) at 10Mbps on NS-104UT-MAQ, NS-516UT-GAQ, and NS-524UT-GAQ with VLAN switch ON

## Sample Installation

1. Determine the best location for the switch.
  - NOTE:** The uplink cable (as well as the PoE device cable, except for the NS-104UT-MAQ, NS-516UT-GAQ, and NS-524UT-GAQ with the VLAN function switch turned ON) cannot exceed 328ft (100m).
2. If installing the NS-104UT-MAQ, NS-516UT-GAQ, or the NS-524UT-GAQ, make sure that the VLAN function switch is set correctly.
3. Turn off power to both the display device and the PoE device before proceeding. Installation under power will damage the transmission equipment.
4. Connect the PoE device(s) to a downlink port on the switch using a Cat5e/6 cable conforming to either the EIA/TIA 568A or 568B standard.
5. Connect the NVR or computer to the uplink port on the switch using a Cat5e/6 cable conforming to either the EIA/TIA568A or 568B standard.
6. Connect the power to the switch and ensure that the power LED and the PoE LED on any connected port is on.
7. Turn on the display device and ensure that the system is functioning properly.

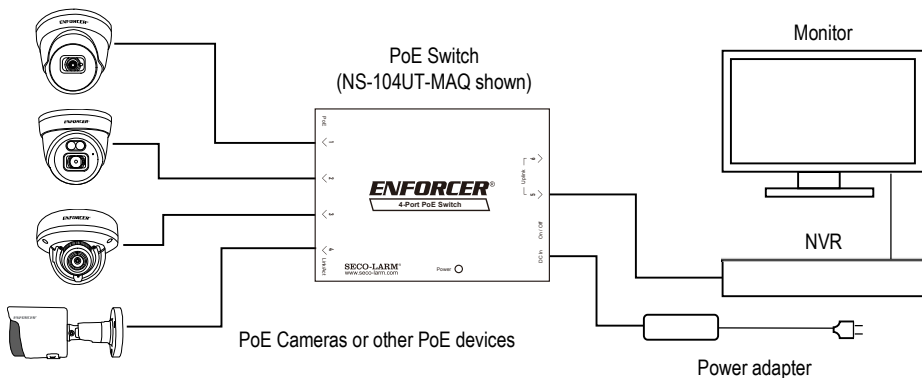

## Troubleshooting

PoE Device doesn't function correctly

- Confirm that both input and output devices are turned on
- Ensure that the Ethernet cable does not exceed 328ft (100m) or 656ft (200m) for the NS-104UT-MAQ, NS-516UT-GAQ, and NS-524UT-GAQ with VLAN function switch turned ON
- Confirm that no PoE equipment power requirement exceeds 30W
- Confirm that the Ethernet cable meets EIA/TIA 568A or 568B standard and that both ends are the same standard (not a crossover cable)
- Test the Ethernet cable to ensure that it is operational
- Test with another PoE device that is known to be operating correctly

---

### FCC COMPLIANCE STATEMENT

THIS DEVICE COMPLIES WITH PART 15 OF THE FCC RULES. OPERATION IS SUBJECT TO THE FOLLOWING TWO CONDITIONS: (1) THIS DEVICE MAY NOT CAUSE HARMFUL INTERFERENCE AND (2) THIS DEVICE MUST ACCEPT ANY INTERFERENCE RECEIVED, INCLUDING INTERFERENCE THAT MAY CAUSE UNDESIRE OPERATION.

Notice: The changes or modifications not expressly approved by the party responsible for compliance could void the user's authority to operate the equipment.

IMPORTANT NOTE: To comply with the FCC RF exposure compliance requirements, no change to the antenna or the device is permitted. Any change to the antenna or the device could result in the device exceeding the RF exposure requirements and void user's authority to operate the device.

**IMPORTANT:** Users and installers of this product are responsible for ensuring this product complies with all national, state, and local laws and statutes related to monitoring and recording audio and video signals. SECO-LARM will not be held responsible for the use of this product in violation of any current laws or statutes.

**IMPORTANT:** Users and installers of this product are responsible for ensuring that the installation and configuration of this product complies with all national, state, and local laws and codes. SECO-LARM will not be held responsible for the use of this product in violation of any current laws or codes.

**California Proposition 65 Warning:** These products may contain chemicals which are known to the State of California to cause cancer and birth defects or other reproductive harm. For more information, go to [www.P65Warnings.ca.gov](http://www.P65Warnings.ca.gov).

**WARRANTY:** This SECO-LARM product is warranted against defects in material and workmanship while used in normal service for one (1) year from the date of sale to the original customer. SECO-LARM's obligation is limited to the repair or replacement of any defective part if the unit is returned, transportation prepaid, to SECO-LARM. This Warranty is void if damage is caused by or attributed to acts of God, physical or electrical misuse or abuse, neglect, repair or alteration, improper or abnormal usage, or faulty installation, or if for any other reason SECO-LARM determines that such equipment is not operating properly as a result of causes other than defects in material and workmanship. The sole obligation of SECO-LARM and the purchaser's exclusive remedy, shall be limited to the replacement or repair only, at SECO-LARM's option. In no event shall SECO-LARM be liable for any special, collateral, incidental, or consequential personal or property damage of any kind to the purchaser or anyone else.

**NOTICE:** The SECO-LARM policy is one of continual development and improvement. For that reason, SECO-LARM reserves the right to change specifications without notice. SECO-LARM is also not responsible for misprints. All trademarks are the property of SECO-LARM U.S.A., Inc. or their respective owners. Copyright © 2023 SECO-LARM U.S.A., Inc. All rights reserved.

---

## SECO-LARM® U.S.A., Inc.

16842 Millikan Avenue, Irvine, CA 92606  
Phone: (949) 261-2999 | (800) 662-0800

Website: [www.seco-larm.com](http://www.seco-larm.com)  
Email: [sales@seco-larm.com](mailto:sales@seco-larm.com)



MI\_NS-xxxUT-xAQ\_230907.docx