

Access Power Controller Boards

Installation Manual

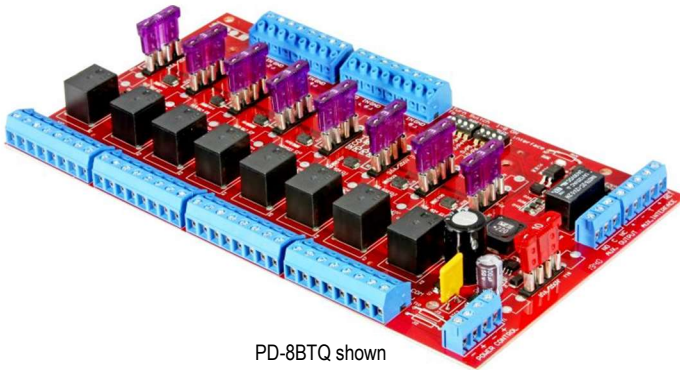

PD-8BTQ shown



Model	Output Fuse Type	Output Fuse Rating	No. of Outputs	Main Fuse
PD-4BTQ	Blade	3.0A	4	10A
PD-4PTQ*	PTC	2.5A	4	10A
PD-8BTQ	Blade	3.0A	8	10A
PD-8PTQ*	PTC	2.5A	8	10A

*Special order only

ENFORCER 4- and 8-Output Access Power Controller Boards centralize power sources and give individual control of locking devices, such as maglocks, electric shear locks, door strikes, deadbolt locks, and more. Outputs are individually controllable, individually fused, with individual status LEDs, and operate in fail-safe or fail-secure modes. They include auxiliary supervision relays, power failure supervision relays, and wet and dry trigger inputs for emergency activation.

- For 12/24 VAC/VDC operation
- Individual output relays (10A@24VDC), individually fused, fuses rated at 3.0A (PTC@2.5A)
- Each individually controlled and can operate in both fail-safe and fail-secure modes
- Individual status LEDs for each output and for emergency input
- Auxiliary supervision relay (1A@28VDC)
- Equipped with dry and wet trigger inputs (blade versions only)
- Auxiliary interface enable emergency egress, alarm monitoring, or triggers other devices
- Includes auxiliary interface disconnect, individually selectable for each output
- Compatible with ENFORCER Access Control Power Supplies

Parts List

1x Power controller board

4x Mounting spacers

1x Manual

Specifications

Model	PD-4BTQ	PD-4PTQ*	PD-8BTQ	PD-8PTQ*
Input voltage	12/24 VAC/VDC			
Input current draw	10A@24VAC			
No. of outputs	4		8	
Output voltage	12VDC			
Output fuses	4x Blade 3.0A	4x PTC 2.5A	8x Blade 3.0A	8x PTC 2.5A
Output relays	Form C (10A@12VDC)			
Auxiliary Interface (AICP)	NO/NC/COM/+INP-/T/+RET-			
Auxiliary Form C output	DPDT (1A@28VDC)			
LED Status	4 (red, on when relay is energized)		8 (red, on when relay is energized)	
Indicators AICP	1 (green on when auxiliary input is triggered or alarm condition)			
Main (input) fuse	10A			
Operating humidity	0~95% non-condensing			
Operating temperature	-40°~167° F (-40°~75° C)			
Dimensions	5 ³ / ₈ "x3 ⁵ / ₈ "x1 ⁵ / ₁₆ " (136x92x23 mm)		8"x5 ¹ / ₁₆ "x1 ⁵ / ₁₆ " (204x129x23 mm)	
Weight	4.8-oz (137g)	4.9-oz (140g)	8.9-oz (252g)	9.1-oz (257g)

*Special order only

Overview

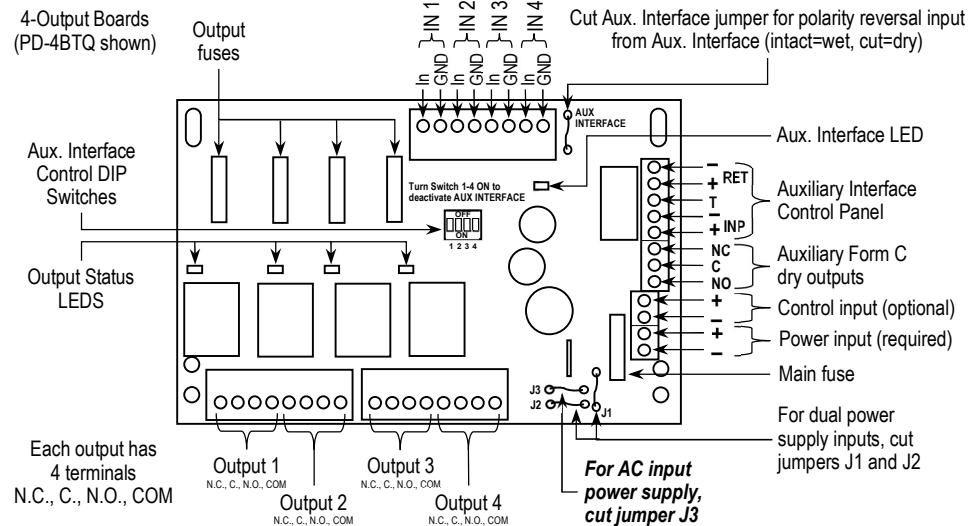

Overview (Continued)

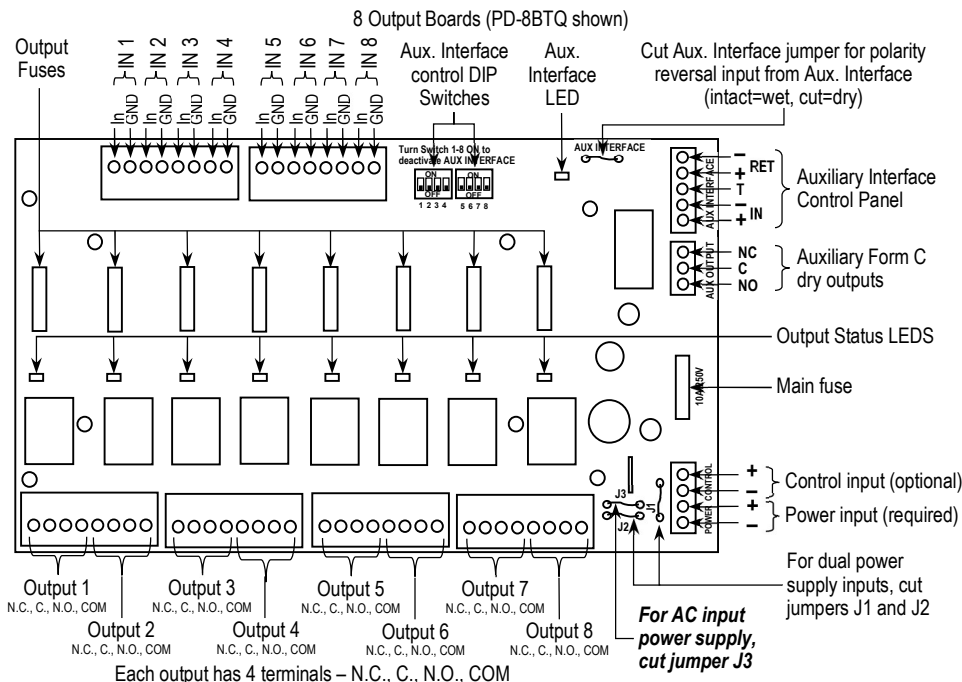

Terminal Overview

Terminal Group	Terminal Labels	Description of Use or Function
Power	+, -	12~24 VAC/VDC Power supply (required)
Control	+, -	Can be connected to a second 12~24 VAC/VDC power supply for isolated operating power (optional)
Inputs (Trigger)	┌1┐ ~ ┌4┐ (or ~ ┌8┐*) IN, GND	Inputs from either N.O. or open collector sink inputs e.g., RTE buttons, access control output relays, PIR sensors, keypads, etc. Each input corresponds to the same numbered output.
Outputs	┌Output 1┐ ~ ┌Output 4┐ (or ~ ┌Output 8┐*) NC, C, NO, COM	12~24 VAC/VDC trigger controlled outputs: 1. Fail-safe devices to N.C. positive and COM negative, 2. Fail-secure devices to N.O. positive and COM negative, 3. Auxiliary output to C positive and COM negative, NOTES: • When using AC power input, polarity is not important. • NC, C, and NO become Form C dry outputs (5A@24VAC/VDC) when corresponding fuse is removed.
Auxiliary Interface Control Panel Inputs	+, -, T, +, RET (-)	Alarm trigger input (either N.C. or N.O.) from Auxiliary Interface Control Panel's output circuit (see Figs. 1~5, pg. 7)
Auxiliary Interface Control Panel Outputs	NO, C, NC	Form C relay contact (1A@28VDC) for alarm reporting

*PD-8PTQ and PD-8BTQ

Installation Notes

1. DIP Switches control whether an individual output should be triggered by the auxiliary interface (default is "OFF," not controlled).
2. When using a single power supply:
 - a. Connect the output to the positive and negative terminals marked *Power*.
3. When using two power supplies:
 - a. Cut the jumpers noted in the overview diagrams on pg. 2 or pg. 3.
 - b. Connect power controller board power to the positive and negative terminals marked *Control*.
 - c. Connect power for the locking devices to the positive and negative terminals marked *Power*.

NOTES

- When using DC power supply, polarity must be observed.
 - **When using AC power supply, cut jumper J3.**
4. Each output can provide a switched power output, a Form C dry output, or both, as well as an unswitched auxiliary power output. See the "Typical Application" on pg. 6.
-

Installation

Prior to installation, ensure that you are familiar with the various options and their requirements noted in the *Overview*, *Installation Notes*, *Typical Application*, and *Wiring for Various Auxiliary Interface Control Panel Installations* sections.

1. Mount the board in a supply box, making sure to use compatible spacers between the board and the metal back (see pg. 8 for ENFORCER Access Control Power Supply instructions).
2. Connect the main power supply to the power controller board terminals marked *Power*.
3. If using two power supplies, connect the second power supply to the power controller board *Control* terminals and cut the jumpers *J1* and *J2* (see *Overview*, pg. 2 for 4-output boards and pg. 3 for 8-output boards). Be sure **not** to cut jumper *J3* unless using AC power supplies.

NOTES

- When using DC power, be careful to observe polarity when connecting power supplies.
 - **When using AC power, be sure to cut jumper J3.**
 - The input marked *Control* is only used for a second power supply but never with a single power supply.
4. Connect each controlled device to one of the 4 or 8 outputs. Note the various connection examples shown in the *Typical Application* section (see pg. 6).
 - a. Switched power outputs
 - i. Connect the powered device negative input to the *COM* terminal.
 - ii. For fail-safe operation, connect the powered device positive input to the *NC* terminal.
 - iii. For fail-secure operation, connect the powered device positive input to the *NO* terminal.
 - b. Dry Form C outputs
 - i. Remove the corresponding fuse for the output.
 - ii. Connect the powered device negative input directly to the power supply negative input.
 - iii. Connect the power supply's positive terminal to the power controller board output terminal for this device marked *C*.
-

Installation (Continued)

- iv. For fail-safe operation, connect the powered device positive input to the *NC* terminal.
- v. For fail-secure operation, connect the powered device positive input to the *NO* terminal.
- c. Unswitched auxiliary power outputs (to provide power to card readers, keypads, etc.)
 - i. Connect the powered device positive input to the *C* terminal.
 - ii. Connect the powered device negative input to the *COM* terminal.

NOTE: Keep power limited wiring separated from non-power limited wiring (AC input, battery wiring) by a minimum distance of 1/4" (7mm) and use separate knockouts in the enclosure.

- 5. Connect each controlling device (card reader, keypad, RTE plate, etc.) to the corresponding input terminal for the particular device to be controlled. Inputs are activated by normally open or open collector sink inputs.
 - a. Normally open (N.O.) input triggers
 - i. Connect the devices to the terminals marked *IN* and *GND* that correspond to the power output terminals of the device to be controlled.
 - b. Open collector sink inputs
 - i. Connect the access control panel open collector output to the power controller board's *IN* input terminal.
 - ii. Connect the access control panel open collector's common (negative) to the power controller board's *GND* input terminal.
- 6. Connect an Auxiliary Interface Control Panel (AICP) to the power controller board's Aux. Interface to allow a NO, NC, or polarity reversal input from an AICP signaling circuit to trigger selected outputs. To enable AICP disconnect for any output, set its corresponding DIP switch to *ON*. To disable AICP disconnect for any output, set its DIP switch to *OFF* (default, *OFF*).
 - a. Normally open (N.O.) input
 - i. For a non-latching hookup, refer to the instructions for Fig. 1 on pg. 7.
 - ii. For a latching hookup, refer to the instructions for Fig. 4 on pg. 7.
 - b. Normally closed (N.C.) input
 - i. For a non-latching hookup, refer to the instructions for Fig. 2 on pg. 7.
 - ii. For a latching hookup, refer to the instructions for Fig. 5 on pg. 7.
 - c. AICP Signaling circuit input trigger
 - i. For a polarity reversal input from the AICP Auxiliary Output, refer to the instructions for Fig. 3 on pg. 7.
- 7. The AICP Auxiliary Output may also be connected as a dry Form C output as follows:
 - a. Connect the device to be triggered by the unit's dry contact output to the power controller board's Aux. Interface terminals as follows:
 - i. For normally open output, connect to the *NO* and *C* terminals.
 - ii. For normally closed output, connect to the *NC* and *C* terminals.

NOTE: The unit should be tested at least once a year for proper operation. Test voltage on each output for both triggered and untriggered states and simulate the operation of the AICP.

Typical Application

PD-4BTQ shown

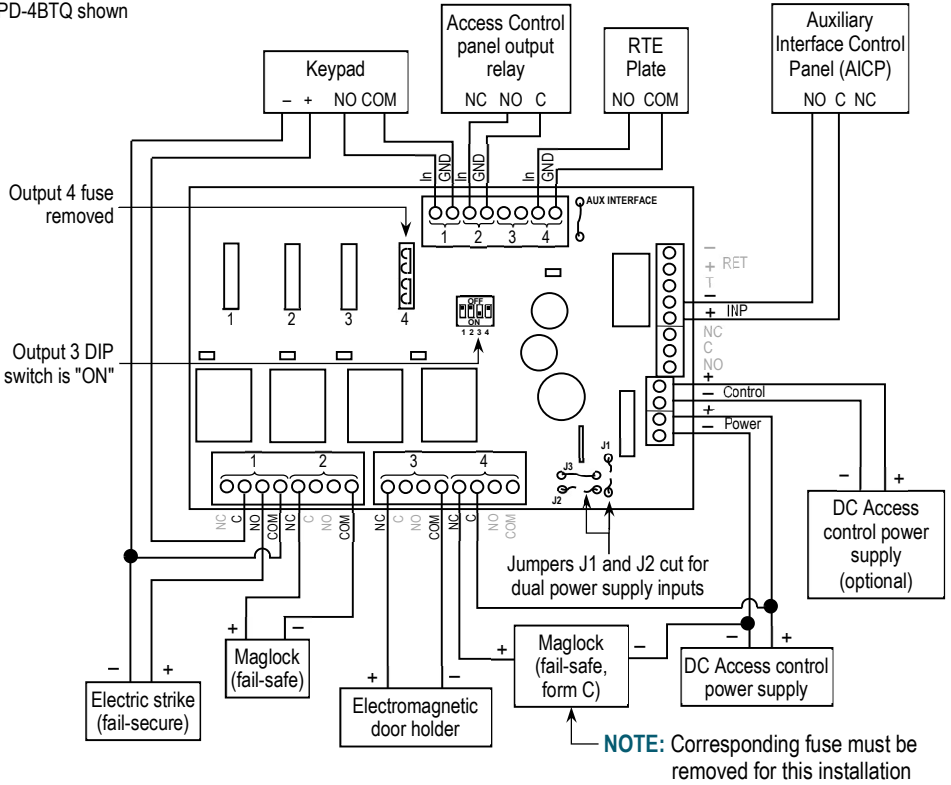

1. In this example, each input is activated by an N.O. trigger input. Controlling devices' (keypads, RTE plates, card readers, etc.) outputs are connected to the *In* and the *GND*.
2. Switched devices (outputs 1~4) include both fail-safe and fail-secure examples.
3. A keypad is connected both to control the electric strike, but also to the *C* and *COM* outputs for auxiliary power.
4. Output 3 is triggered by the *Auxiliary Interface* (controlled by the *Aux. Interface* DIP switches).
5. Output 4 is an example of a Form C dry contact installation. For this application, the corresponding fuse has been removed.
6. A single power supply must be connected to the power inputs marked *Power*.
7. When using two power supplies, the second is connected to the two power inputs marked *Control*. In this case, the two jumpers *J1* and *J2* marked above must also be cut.
8. In this example, the *Auxiliary Interface's* N.O. (or N.C. for normally closed installations) and *C* outputs are connected as Form C dry contacts (see pg. 7 for other options).

Wiring for Various Auxiliary Interface Control Panel Installations

1. For **normally open, non-latching** Auxiliary Interface Control Panel (AICP) input, connect an N.O. trigger to the *INP +* and *T* Aux. Interface terminals (see Fig. 1).

Fig. 1

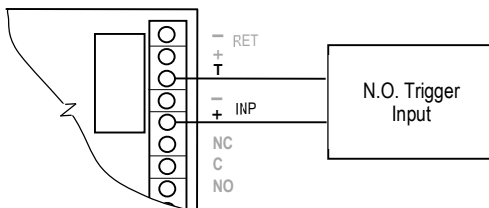

2. For **normally closed, non-latching** AICP input, connect an N.C. trigger to the *INP -* and *T* Aux Interface terminals. Add a jumper between the *INP +* and *T* terminals (see Fig. 2).

Fig. 2

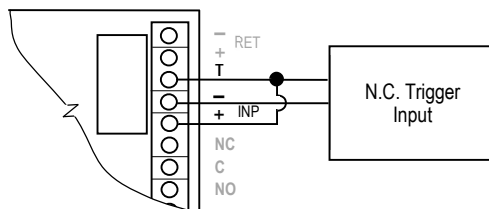

3. For a **polarity reversal input** from the AICP output, connect the + and - terminals from the AICP control circuit to the two terminals + *INP -* on the Aux. Interface, observing polarity. If an AICP control circuit EOL is used, connect that to the two terminals + *RET -* terminals on the Aux. Interface (see Fig. 3). Cut the *Aux Interface jumper* near the *Aux Interface* (see the corresponding *Overview* on pg. 2 or 3).

Fig. 3

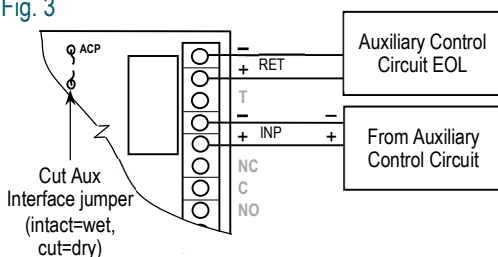

4. For a **normally open, latching** AICP trigger input with reset, connect an N.O. trigger input to the *INP +* and *T* Aux Interface terminals. Add a jumper between the *INP +* and *C* terminals. Connect an N.C. reset switch to the *T* and *N.O.* terminals (see Fig. 4).

Fig. 4

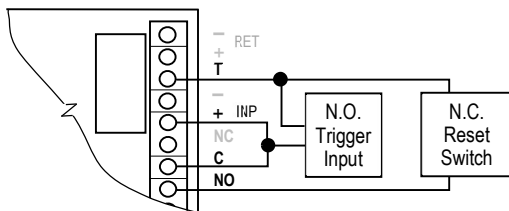

5. For a **normally closed, latching** AICP trigger input with reset, connect an N.C. trigger input to the *INP -* and *C* Aux Interface terminals. Add a jumper between the *INP +* and *N.C.* terminals. Connect an N.O. reset switch to the *INP +* and *T* terminals (see Fig. 5).

Fig. 5

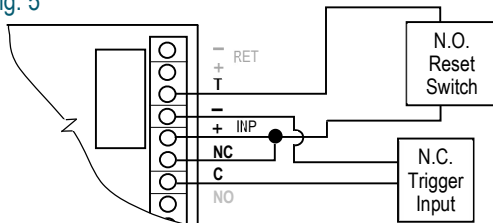

Installing in ENFORCER Access Control Power Supply

For installation in an ENFORCER Access Control Power Supply enclosure follow the steps below (see Fig. 6).

1. Place the Access Power Controller Board (APCB) inside the enclosure to note which four mounting holes match.
2. From the back side of the enclosure, insert the four nylon mounting spacers (included) through the four holes indicated in step 1, pressing them in firmly until you hear the click of the enclosure mounting spring lock.
3. Align the four holes in the APCB to the nylon mounting spacers and press firmly until you hear the click of the board mounting spring lock.
4. Connect the APCB power input to the power supply circuit board's DC output terminal according to the wiring diagram on pg. 6.

Fig. 6

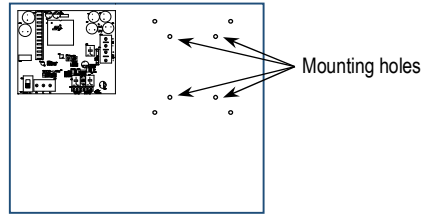

ENFORCER
EAP-5D1Q shown

Nylon mounting spacers

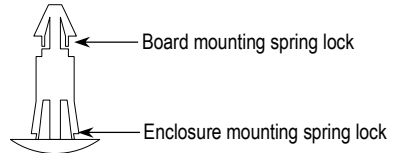

Troubleshooting

No DC output	<ul style="list-style-type: none">• Check whether the AC input voltage or backup battery voltage is normal.
Low DC voltage output	<ul style="list-style-type: none">• Check whether the output voltage setting is correct.• Check whether the AC input wattage is correct (see chart, pg. 3).• If the battery is supplying power, check whether the battery voltage is normal.• Check whether the power supply board is overloaded.
No backup battery power	<ul style="list-style-type: none">• Check whether the battery voltage is normal or already discharged.• Check whether the master fuse has burned out.

IMPORTANT: Users and installers of this product are responsible for ensuring that the installation and configuration of this product complies with all national, state, and local laws and codes. SECO-LARM will not be held responsible for the use of this product in violation of any current laws or codes.

California Proposition 65 Warning: These products may contain chemicals which are known to the State of California to cause cancer and birth defects or other reproductive harm. For more information, go to www.P65Warnings.ca.gov.

WARRANTY: This SECO-LARM product is warranted against defects in material and workmanship while used in normal service for one (1) year from the date of sale to the original customer. SECO-LARM's obligation is limited to the repair or replacement of any defective part if the unit is returned, transportation prepaid, to SECO-LARM. This Warranty is void if damage is caused by or attributed to acts of God, physical or electrical misuse or abuse, neglect, repair or alteration, improper or abnormal usage, or faulty installation, or if for any other reason SECO-LARM determines that such equipment is not operating properly as a result of causes other than defects in material and workmanship. The sole obligation of SECO-LARM and the purchaser's exclusive remedy, shall be limited to the replacement or repair only, at SECO-LARM's option. In no event shall SECO-LARM be liable for any special, collateral, incidental, or consequential personal or property damage of any kind to the purchaser or anyone else.

NOTICE: The SECO-LARM policy is one of continual development and improvement. For that reason, SECO-LARM reserves the right to change specifications without notice. SECO-LARM is also not responsible for misprints. All trademarks are the property of SECO-LARM U.S.A., Inc. or their respective owners. Copyright © 2025 SECO-LARM U.S.A., Inc. All rights reserved.

SECO-LARM® U.S.A., Inc.

16842 Millikan Avenue, Irvine, CA 92606
Phone: (949) 261-2999 | (800) 662-0800

Website: www.seco-larm.com
Email: sales@seco-larm.com

 PITSW1
Order Part# 764-042-2%
ML_PD-xxTQ_250416.docx